

# Dimensioning Fundamentals



## Learning Objectives

After studying this chapter, you will be able to:

- Define size and location dimensions.
- Explain the drawing conventions used for dimension, extension, and leader lines.
- Describe standard conventions used in inch dimensioning and metric dimensioning.
- Identify and explain common dimensioning systems used in drafting.
- Explain the purpose of general and local notes.
- List the general rules for good dimensioning practice.
- Describe the common commands and methods used in dimensioning CAD drawings.
- Dimension drawings using accepted conventions.

## Technical Terms

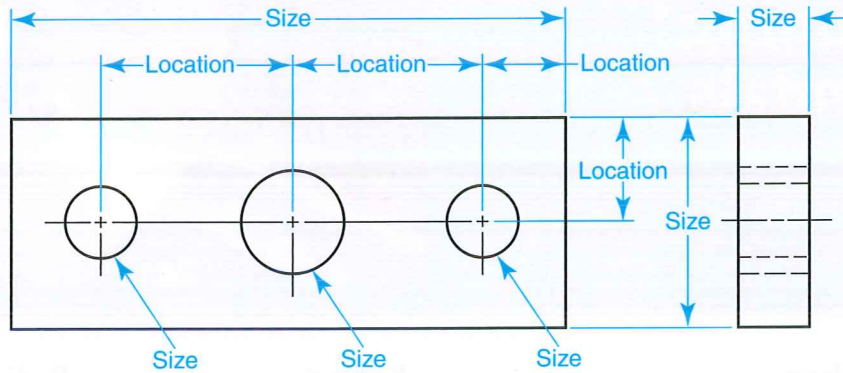
Aligned dimensioning	Dimensional notes
Angular dimensions	Dimensioning
Arrowheads	Dimensioning commands
Arrowless dimensioning	Dimension line
Chain dimensioning	Dimension style
Coordinate dimensioning	Dual dimensioning
Counterbore	Extension lines
Counterdrill	Flag
Countersink	Fractional dimensioning
Datum dimensioning	General notes
Decimal inch dimensioning	International System of Units

Keyseat	Radial dimensions
Knurls	Rectangular coordinate dimensioning
Leader dimensions	SI Metric system
Leaders	Size dimensions
Linear dimensions	Spotface
Local notes	Tabular dimensioning
Location dimensions	Tolerances
Metric dimensioning	Undercut
Ordinate dimensioning	Unidirectional dimensioning
Point-to-point dimensioning	
Polar coordinate dimensioning	

**D**imensioning is the process of defining the size, form, and location of geometric components on drawings. It is one of the most important operations in producing a detail drawing and should be given very careful attention. Standard conventions for dimensioning are provided by the ASME Y14.5M standard, published by the American Society of Mechanical Engineers.

Two general types of dimensions are used on drawings. These are size dimensions and location dimensions, **Figure 9-1**. *Size dimensions* define the size of geometric components of a part. The diameter of a cylinder and the width of a slot are examples of size dimensions. *Location dimensions* define the location of these geometric components in relation to each other. The distance from the edge of a part to the center of a hole is an example of a location dimension.





**Figure 9-1.** Size dimensions and location dimensions provide information about the size and location of features on drawings.

## Elements in Dimensioning

A standard set of lines and notes are recommended for use on drawings. All lines used in dimensioning are drawn as thin lines, **Figure 9-2**. In manual drafting, dimensions are drawn using a 2H or 4H lead for the individual elements. In CAD drafting, dimensions are drawn using thin linetypes for the individual elements. Dimensioning elements are discussed in the following sections.

### Dimension Lines

A *dimension line* is a line with termination symbols (generally arrowheads) at each end to indicate the direction and extent of a dimension, **Figure 9-2A**. The dimension line may be broken and the dimension numeral inserted, **Figure 9-2B**. The dimension line may also be a full, unbroken line with the dimension numeral located above or below it. Refer to **Figure 9-2A**. However, broken and full dimension lines should not be used on the same drawing.

The first dimension line is spaced .375" to 1" (10 mm to 25 mm) from the view, depending on space available on the drawing. Refer to **Figure 9-2A**.

The standard practice is to keep dimension lines away from the view for greater clarity. When the minimum distance of .375" is used, adjacent dimension lines should be spaced at least .25" apart. Dimensions spaced 1" or more from the view may have subsequent lines spaced less than 1", depending on the size of the drawing.

### Extension Lines

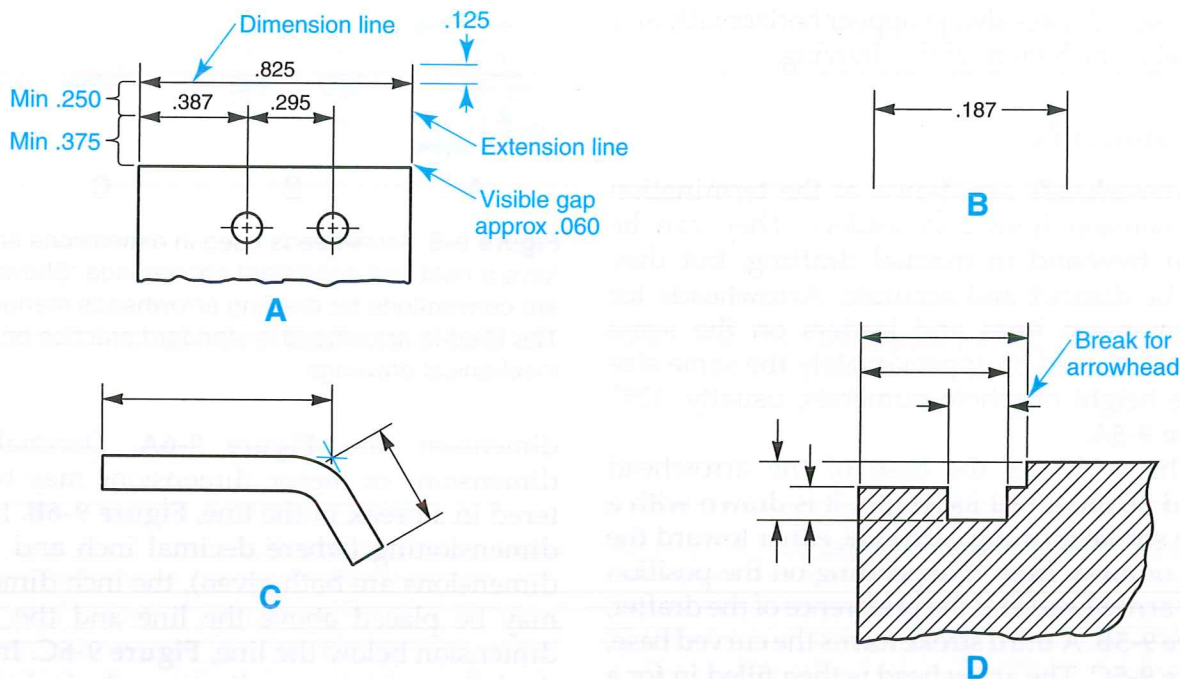
*Extension lines* are used to indicate the termination of a dimension. Refer to **Figure 9-2A**. They are usually drawn perpendicular to the dimension line with a visible gap of approximately .06" (1.5 mm) from the object. Extension lines extend approximately .125" (3 mm) beyond the dimension line. When extension lines are used to locate a point, they must pass through the point as in **Figure 9-2C**.

Crossing dimension or extension lines with other lines should be avoided by placing the shortest dimensions nearest the object and progressing outward according to size. Dimension lines should be located so they are not crossed by any line. When it is necessary to cross a dimension line with an extension line, the extension line is broken, **Figure 9-2D**.

### Leaders

*Leaders* are thin, straight lines that lead from a note or dimension to a feature on the drawing. Leaders terminate with an arrowhead or dot, **Figure 9-3**. Leaders that terminate on an edge or at a specific point should end with an arrowhead. Dots are used with leaders that terminate inside the outline of an object, such as a flat surface.

The dimension or note end of the leader contains a horizontal bar approximately .125" in length. Preferably, the leader angle (the angle at which the leader line is projected from the object) should be 45° to 60°. Leaders should never be drawn parallel to extension or dimension lines. Leaders drawn to a circle or circular arc should be in line with the center of the particular feature.

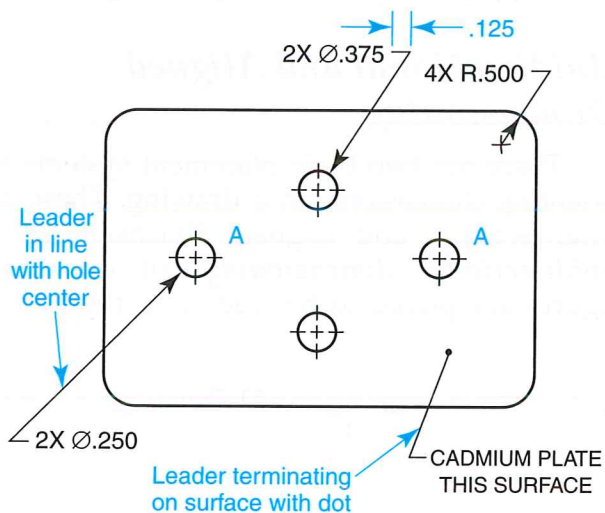


**Figure 9-2.** Lines used in dimensioning are drawn thin. Shown are conventions for drawing dimension lines and extension lines. A—Dimension lines indicate the direction and extent of a dimension. Extension lines indicate the termination of a dimension. They extend past the dimension line. B—The dimension line may be broken to insert the dimension numeral (as shown), or the numeral may be placed above or below the dimension line. C—Extension lines used to locate a point must pass through the point. D—An extension line is broken when it is necessary to cross a dimension line.

### Dimensioning repetitive features

It is standard dimensioning practice to use a multiplication sign (X) to indicate a number of repetitive features. For example, the leader note

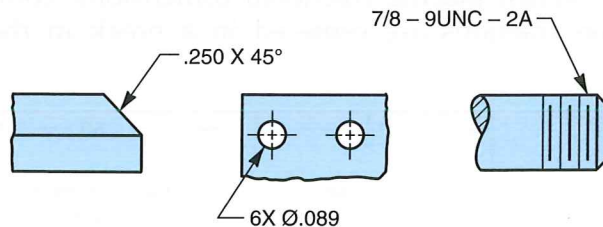
2X  $\varnothing$ .375 indicates two holes each with a diameter of .375. Refer to **Figure 9-3**. This provides for clarity and speed in drafting.



**Figure 9-3.** Leaders are used to provide dimensions for holes and radii and to provide an indication of the feature being described in a note.

### Dimensional notes

*Dimensional notes* are notes commonly placed with leaders to describe the size or form of features, such as hole specifications, chamfers, and threads, **Figure 9-4**. They serve the same purpose as dimensions. Dimensional notes are also used with dimension and extension lines to provide specific information about details on the drawing.



**Figure 9-4.** Dimensional notes with leaders are used to describe size and form, or to provide additional information not communicated elsewhere.



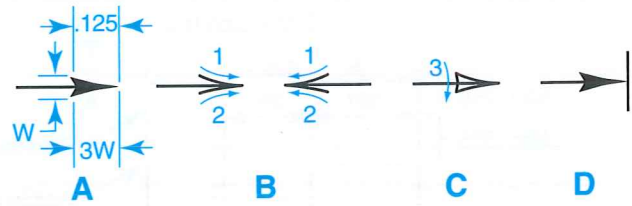
Dimensional notes always appear horizontally and parallel to the bottom of the drawing.

### Arrowheads

*Arrowheads* are drawn at the termination of dimension lines and leaders. They can be drawn freehand in manual drafting, but they must be distinct and accurate. Arrowheads for all dimension lines and leaders on the same drawing should be approximately the same size as the height of whole numerals, usually .125", **Figure 9-5A**.

The width of the base of the arrowhead should be one-third its length. It is drawn with a single stroke forming each side, either toward the point or away from it depending on the position of the arrowhead and the preference of the drafter, **Figure 9-5B**. A third stroke forms the curved base, **Figure 9-5C**. The arrowhead is then filled in for a distinctive appearance, **Figure 9-5D**.

In CAD drafting, arrowheads are placed automatically with dimension lines and extension lines when using dimensioning commands. Controls are provided for setting the arrowhead size and style.



**Figure 9-5.** Arrowheads used in dimensions should have a neat and consistent appearance. Shown are conventions for drawing arrowheads manually. The filled-in arrowhead is standard practice on mechanical drawings.

dimension line, **Figure 9-6A**. Decimal inch dimensions or metric dimensions may be centered in a break in the line, **Figure 9-6B**. In dual dimensioning (where decimal inch and metric dimensions are both given), the inch dimension may be placed above the line and the metric dimension below the line, **Figure 9-6C**. In some dual dimensioning applications, the inch dimension is shown above the line followed by the metric dimension in parentheses, **Figure 9-6D**.

A comma is used in place of a decimal point in metric dimensioning in many European countries. However, this practice is not standard for worldwide use.

### Dimension Figures

Dimension figures should be clearly formed to prevent any possibility of being misread. Some drafters use a style of numerals that provides a positive recognition even when a portion of the numeral is lost in reproduction or is not clear on the drawing.

The height of dimension figures is the same as the letter height on the drawing, usually .125". Fractions are twice the height of whole numbers.

### Placing dimension figures

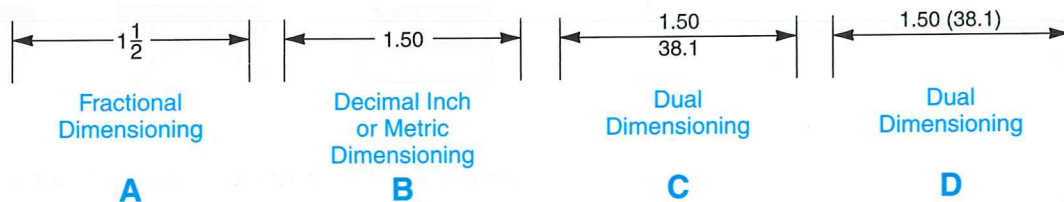
When placing fractional dimensions, common fractions are centered in a break in the

### Placing staggered dimensions

Where a number of dimensions appear in the same area of a drawing, the dimension figures are staggered. This gives the drawing a better appearance and saves space, **Figure 9-7**.

### Unidirectional and Aligned Dimensioning

There are two basic placement systems for orienting dimensions on a drawing. These are unidirectional and aligned dimensioning. In *unidirectional dimensioning*, all dimension figures are placed to be read from the bottom



**Figure 9-6.** Conventions for placing dimension figures on a drawing.



of the drawing, **Figure 9-8A**. This is the recommended standard. In *aligned dimensioning*, all dimensions are placed parallel to their dimension lines and are read from the bottom or right side of the drawing, **Figure 9-8B**.

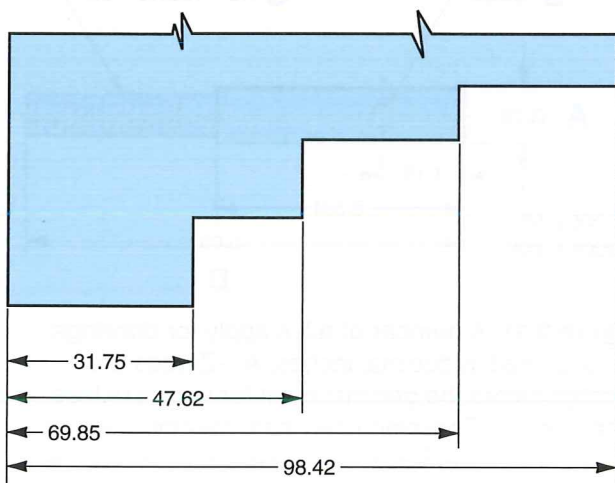
There are orientations that should be avoided in the aligned dimensioning system due to the awkward appearance and difficulty of reading, **Figure 9-9**.

### Dimensioning within the Outline of an Object

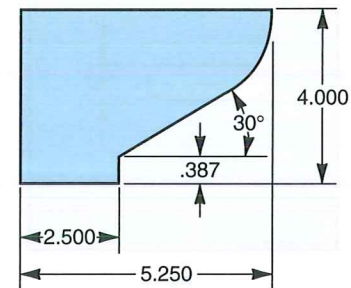
Dimensions should be kept outside the views of an object whenever possible. Exceptions are permissible where the directness of an application makes it necessary, **Figure 9-10A**. When it is necessary to dimension within the sectioned part of a sectional view, the section lines are omitted from the dimension area, **Figure 9-10B**.

## Dimensioning Systems

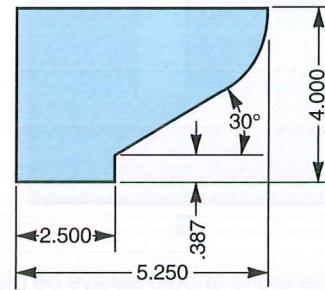
Linear dimensions on a drawing are expressed in decimal inches or common fractions of an inch in the US Customary (English) system of measurement. In the metric system of measurement, dimensions are given as millimeters. In inch dimensioning, when linear dimensions exceed a certain length (from 144" to 192", depending on the particular



**Figure 9-7.** Staggered dimensions are used on drawings to give a better appearance and improve clarity when a number of dimensions are located in the same area.

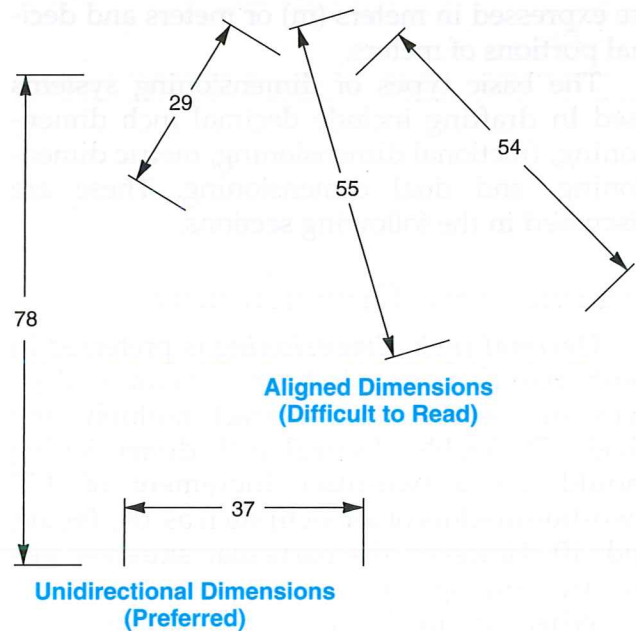


**Unidirectional Dimensioning A**

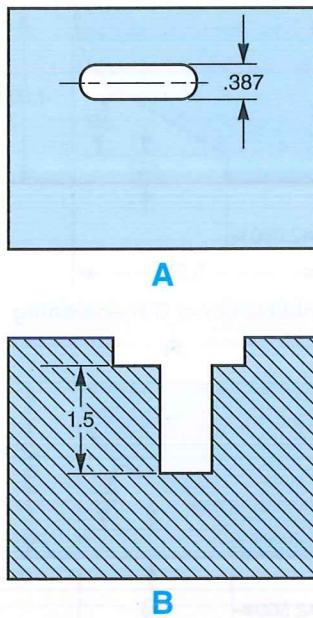


**Aligned Dimensioning B**

**Figure 9-8.** The unidirectional dimensioning system aligns the dimension figures parallel with the bottom edge of the drawing. The aligned dimensioning system aligns the dimension figures with the dimension lines. The figures may be parallel with either the bottom or the right side of the drawing, depending on the feature being described.



**Figure 9-9.** Dimension lines that appear at unusual angles are best dimensioned using the unidirectional dimension system. This makes the dimensions easier to read than aligned dimensions.



**Figure 9-10.** Dimensions should always be placed on the outside of an object when possible. However, in some cases, this is not possible. There are a few cases where dimensions are allowed within the outline of an object.

industry), the dimension value is given in feet and inches. In such cases, abbreviations for feet (ft or ') and inches (in or ") are usually shown after the values. In metric dimensioning, linear dimensions in excess of 10,000 millimeters (mm) are expressed in meters (m) or meters and decimal portions of meters.

The basic types of dimensioning systems used in drafting include decimal inch dimensioning, fractional dimensioning, metric dimensioning, and dual dimensioning. These are discussed in the following sections.

### Decimal Inch Dimensioning

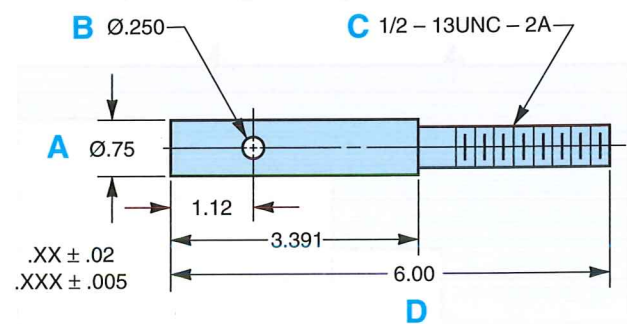
**Decimal inch dimensioning** is preferred in most manufacturing industries because decimals are easier to add, subtract, multiply, and divide. Preferably, decimal inch dimensioning should use a two-place increment of .02" (two-hundredths of an inch) such as .04, .06, .08, and .10. However, the particular situation that you are working with may not permit this.

When decimals of .02" increments are divided by two, the quotient is a two-place decimal as well. Decimal inch dimensions in size increments other than .02" should be used where more exacting requirements must be met.

### Decimal inch dimensioning rules

A number of rules apply when placing dimensions in decimal inches. These are listed as follows.

1. Omit zeroes before the decimal point for values of less than one, **Figure 9-11A**.
2. Common decimal fraction equivalents of .250, .500, and .750 may be shown as two-place decimals unless they are used to designate a drilled hole size, a material thickness, or a thread size, **Figure 9-11B**. Tolerance values can be shown in the title block to specify different tolerances for dimensions having a different number of decimal places.
3. Standard nominal sizes of materials, threads, and other features produced by tools that are designated by common fractions may be shown as common fractions, **Figure 9-11C**. Examples include the following:  
 $3/4-10\text{UNC}-2\text{A}$   
 $\text{Ø}.250 (1/4)$   
 $3/8 \text{ HEX}$
4. Decimal points must be definite, uniform, and large enough to be visible on reduced-size drawings. The decimal point should be in line with the bottom edge of the numerals and letters to which it relates, **Figure 9-11D**.



**Figure 9-11.** A number of rules apply for drawings dimensioned in decimal inches. A—Zeroes are omitted before the decimal point for values of less than one. B—Two-place decimals may be used for common decimal fractions unless the dimension is used to show a drilled hole size, a material thickness, or a thread size. C—Common fractions used for standard nominal sizes may be used for dimensions such as thread notes. D—Decimal points must be uniform in size and clearly visible.



## Rules for rounding off decimals

When it is necessary to round off decimals to a lesser number of places in decimal inch dimensioning, the following rules apply.

1. When the next figure beyond the last digit to be retained is less than 5, use the shortened form unchanged. For example, the number 2.62385 is to be shortened to two decimal places. The third figure beyond the decimal point is 3 (2.62385), which is less than 5. The decimal is rounded off to the number 2.62.
2. When the next figure beyond the last digit to be retained is greater than 5, increase the digit by 1. For example, the number 2.62385 is to be shortened to three decimal places. The fourth figure beyond the decimal point is 8 (2.62385), which is greater than 5. The decimal is rounded off to the number 2.624.
3. When the next figure beyond the last place to be retained is equal to 5 and the last digit of the shortened form is an odd number, increase the last digit by one. For example, the number 2.62375 is to be shortened to four decimal places. The fifth digit beyond the decimal point is 5 (2.62375). The last digit of the shortened form is 7 (2.62375), which is an odd digit. The last digit of the shortened form is increased by one and the number becomes 2.6238.
4. When the next digit beyond the last number to be retained is equal to 5 and the last digit of the shortened form is an even digit, the shortened form remains unchanged. For example, the number 2.62385 is to be shortened to four decimal places. The fifth digit beyond the decimal point is 5 (2.62385). The last digit of the shortened form is an even digit (2.62385). The last digit of the shortened form is left unchanged and the number becomes 2.6238.

## Fractional Dimensioning

*Fractional dimensioning* is commonly used on drawings in architectural and structural drafting. Close tolerances are not as important in these fields. Many times, the materials involved,

such as lumber, are not manufactured to very small tolerances.

A horizontal fraction bar is used with all fractions. It is located at the midpoint of the vertical height of numerals and capital letters. Where older drawings have been dimensioned with common fractions, some manufacturing industries change these fractions to decimals by referring to a conversion chart.

## Metric Dimensioning

*Metric dimensioning*, like decimal inch dimensioning, uses the base-ten number system. This makes it easy to move from one multiple or submultiple to another by shifting the decimal point.

The unit of linear measure in the metric system is the meter. However, the millimeter is used on most drawings dimensioned in the metric system where the linear dimension is less than 10,000 millimeters. The letter abbreviation for millimeters (mm) following the dimension figure is omitted when all dimensions are in millimeters.

The metric system is referred to internationally as the *Systeme International d'Unites* or the *International System of Units*. The universal abbreviation SI indicates this system, which is also commonly referred to as the *SI Metric system*.

## Metric dimensioning rules

1. A period is used for the decimal point in countries that use the English system of measurement and is the ASME standard. Many countries that use the SI Metric system of measurement use a comma for the decimal point.
2. Whenever a numerical value is less than one millimeter, a zero should precede the decimal point.
3. Digits in metric dimensions are not to be separated into groups by use of commas or spaces.
4. Use metric units that are multiples and submultiples of 1000, such as kilometers (km), meters (m), and millimeters (mm), whenever possible. Avoid the use of centimeters (cm).



5. Do not mix SI Metric units with units from a different system. An exception is in dual dimensioning, discussed next.

## Dual Dimensioning

*Dual dimensioning* uses inch and metric dimensions on the same drawing. In dual dimensioning, the inch measurement is usually given in decimal inches and the metric measurement in millimeters. If the drawing is intended primarily for use in the United States, the decimal inch dimension usually appears above the dimension line and millimeters below, **Figure 9-12A**. In countries where the metric system is used, the millimeter dimension is shown above the dimension line and the decimal inch dimension below, **Figure 9-12B**.

Some industries using dual dimensioning place the metric dimension in brackets above the decimal dimension, **Figure 9-12C**. It is recommended that a note be used adjacent to or within the title block to show how the inch and millimeter dimensions are identified, **Figure 9-12D**. It is also recommended that all dual-dimensioned drawings indicate the angle of projection used, to eliminate any confusion when used in different countries, **Figure 9-12E**.

Dual dimensioning is being replaced by drawings that are dimensioned only in metric units. Where drawings are dimensioned in a single system, individual identification of linear units is not required. However, a note on the drawing stating "UNLESS OTHERWISE SPECIFIED, ALL DIMENSIONS ARE IN MILLIMETERS" (or "INCHES") is shown. Where

some inch dimensions are shown on a drawing dimensioned in millimeters, the abbreviation "IN." should follow the inch value. (Note that in this case, a period follows the abbreviation.) On decimal inch drawings, the symbol "mm" should follow the millimeter values.

An example of a drawing using dual dimensioning is shown in **Figure 9-13**. Tables are provided in the Reference Section for conversion of common fractions and decimals to millimeters and vice versa.

## Dimensioning Features for Size

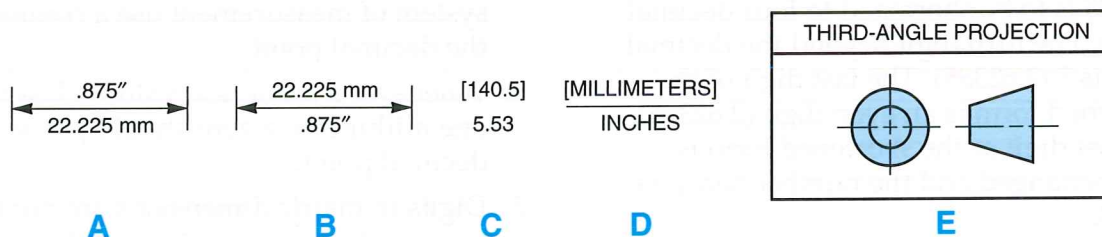
The features of a part or assembly consist of geometric shapes. These shapes may be cylinders, cones, pyramids, or spheres. *Size dimensions* describe the size of each feature.

### Cylinders

Cylinders may be solids (as in projecting stems) or negative volumes (as in holes), **Figure 9-14A**.

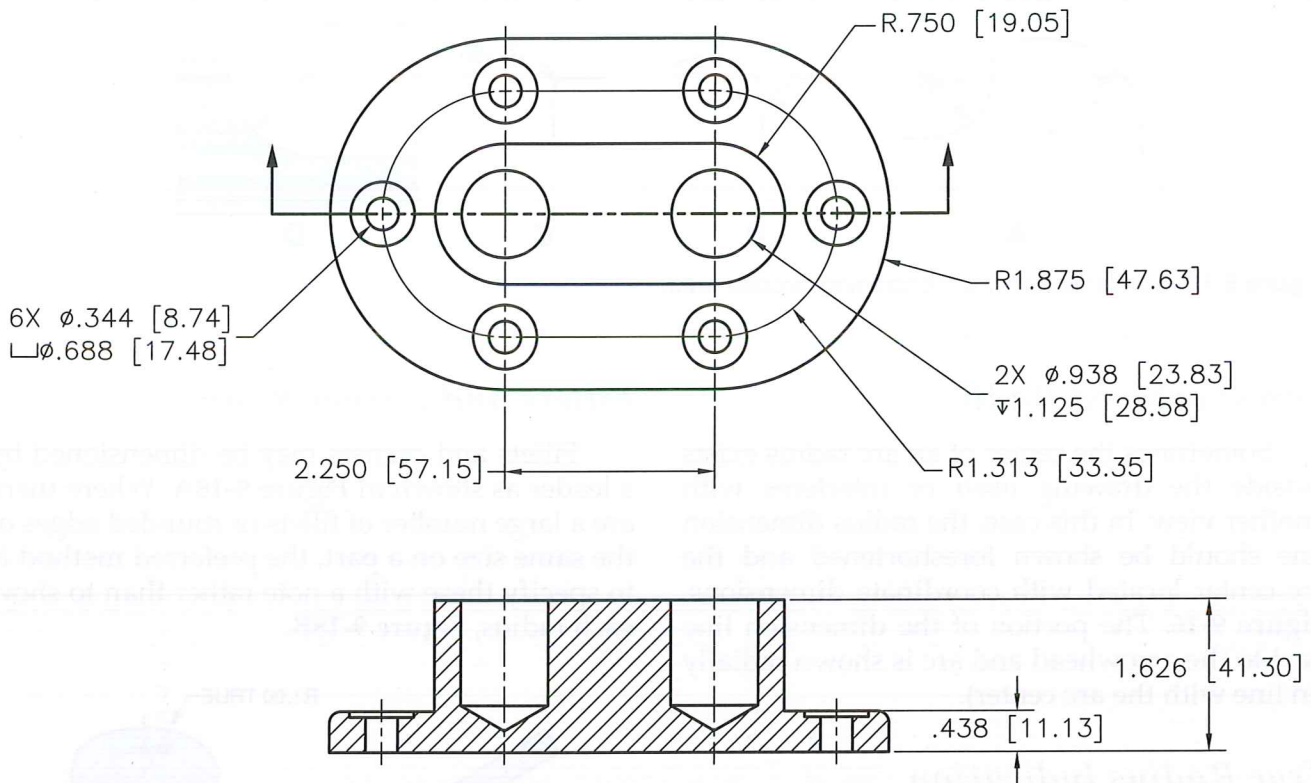
Cylindrical features are dimensioned for diameter and length. In single-view drawings where the feature or part is not shown as a circle, the dimension should be preceded by the symbol for diameter (the international symbol  $\varnothing$ ), **Figure 9-14B**.

Where a leader is used to indicate the diameter, the value of the diameter should be preceded by the symbol for diameter, **Figure 9-14C**.



**Figure 9-12.** There are several ways that dimensions can appear in the dual dimensioning system. In all cases, measurements in both metric units and inches are given. A—The inch dimension is placed above the millimeter dimension when the drawing is primarily used in the United States. B—The millimeter dimension is placed above the inch dimension when the drawing is primarily used in countries using the SI Metric system. C—In some cases, the metric dimension is placed in brackets above the inch dimension. D—A note on the drawing identifies how dual dimensions are given. E—Typically, a symbol indicating what type of projection is being used is also given. This eliminates possible confusion between first-angle and third-angle projections.





NOTES:

1. ALL FILLETS AND ROUNDS  
R1.25 [3.18 mm]
2. DIMENSIONS IN INCHES [MILLIMETERS]

Figure 9-13. A dual-dimensioned drawing.

On views where the cylinder appears as a circle and the dimension is placed on the circular view itself, the diameter symbol is not necessary, Figure 9-14D.

### Circular Arcs

Circular arcs are dimensioned by indicating their radius with a radius dimension line, Figure 9-15. The dimension line is drawn from the radius center and ends with an arrowhead at the arc. The dimension is inserted in the line preceded by the letter "R," Figure 9-15A. Dimensions of radii, where space is limited, may be indicated outside the arc, Figure 9-15B. The dimension may also be placed with a leader when space is limited, Figure 9-15C. A small cross should be used to indicate a radius located by a dimension, Figure 9-15D.

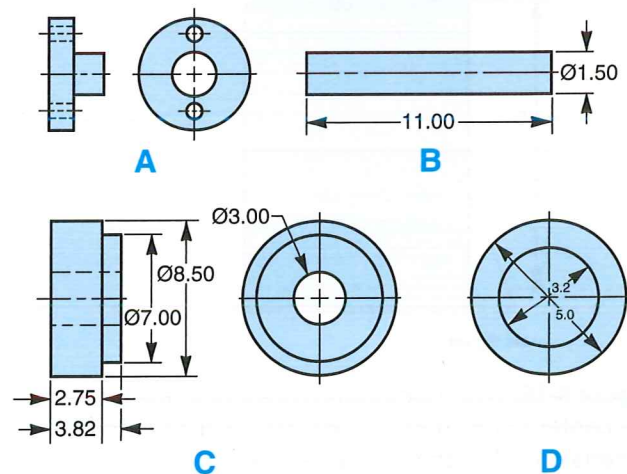


Figure 9-14. Conventions for dimensioning cylinders.

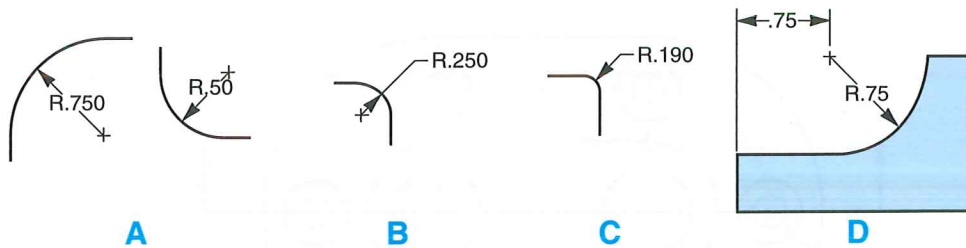


Figure 9-15. Conventions for dimensioning circular arcs.

### Foreshortened Radii

Sometimes the center of an arc radius exists outside the drawing itself or interferes with another view. In this case, the radius dimension line should be shown foreshortened and the arc center located with coordinate dimensions, Figure 9-16. The portion of the dimension line next to the arrowhead and arc is shown radially (in line with the arc center).

### True Radius Indication

A true arc on an inclined surface may be misleading if it is not dimensioned properly. This type of dimension is clarified by the addition of "TRUE" to the radius dimension, Figure 9-17. This indicates "true radius on the surface" and clarifies the information when a radius measurement appears out of scale from the dimension.

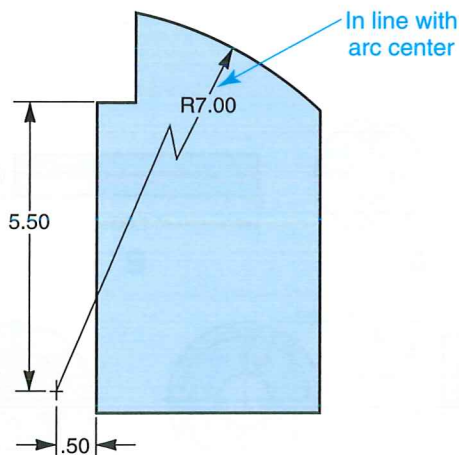


Figure 9-16. When dimensioning a foreshortened radius, the center point should be located with coordinate dimensions. The part of the leader that is close to the arc itself should be drawn in line with the center of the arc. The leader should terminate at the center.

### Fillets and Corner Radii

Fillets and corners may be dimensioned by a leader as shown in Figure 9-18A. Where there are a large number of fillets or rounded edges of the same size on a part, the preferred method is to specify these with a note rather than to show each radius, Figure 9-18B.

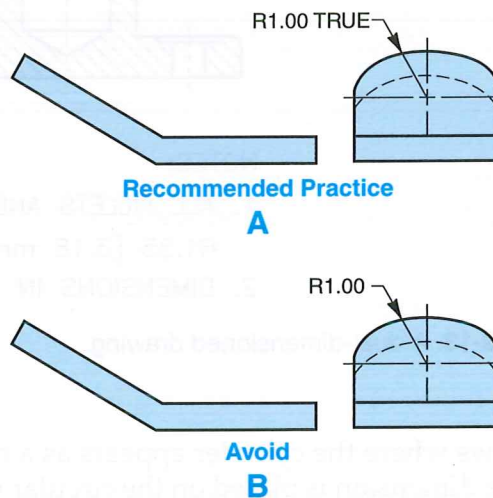


Figure 9-17. When a radius is dimensioned on an inclined surface, the radius will appear out of scale from the dimension. In this case, the word "TRUE" should be added to the dimension for clarity.

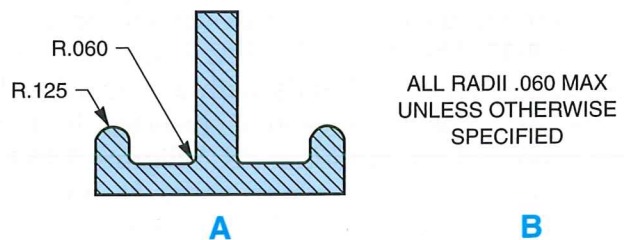


Figure 9-18. Specifying dimensions for fillets and rounded corners. A—Radii can be indicated with a leader and dimension. B—Fillets and corner radii can also be specified with a note.

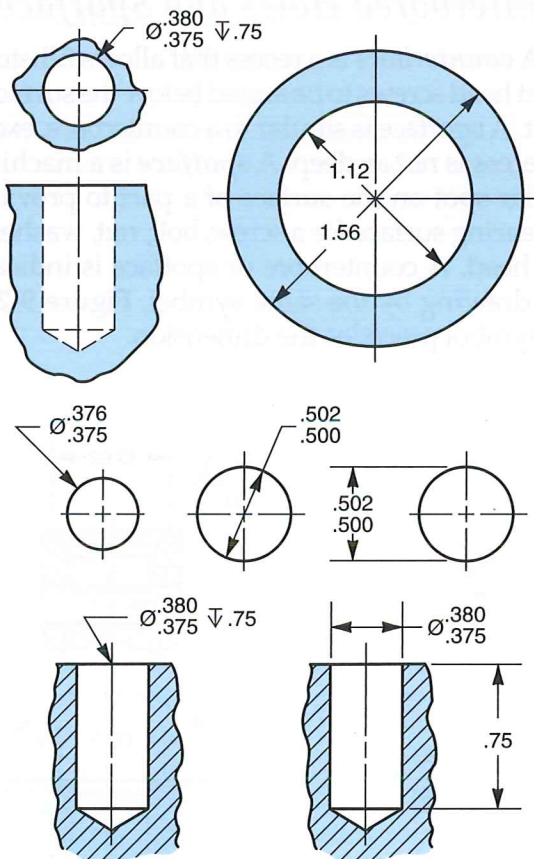


### Round Holes

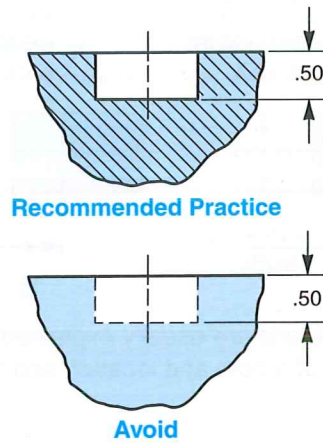
Holes are preferably dimensioned on the view in which they appear as circles. Small holes are dimensioned with leaders and larger holes by dimension lines at an angle (usually 30°, 45°, or 60°) across the diameter, **Figure 9-19**. Holes that are to be drilled, reamed, or punched are specified by indicating the diameter. The depth of holes may be specified by a note or dimensioned in a section view. Additional information on the dimensioning of holes is discussed in Chapter 16.

### Hidden Features

Dimensions should be drawn to object lines (visible lines) whenever possible. Where hidden features exist and are not visible for dimensioning in another view, a section view should be



**Figure 9-19.** Accepted methods for dimensioning round holes. The most appropriate method should be selected for each individual case. (American National Standards Institute)



**Figure 9-20.** Hidden features should not be dimensioned in a view where they appear as hidden lines. Instead, hidden features should be dimensioned in section views whenever possible.

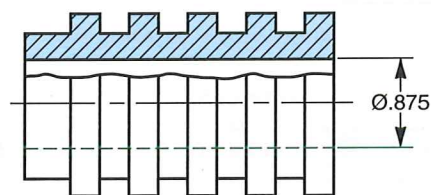
used, **Figure 9-20**. An exception to this general rule is a diameter dimension on a partial section where no other view is used to show the circular diameter, **Figure 9-21**.

### Knurls

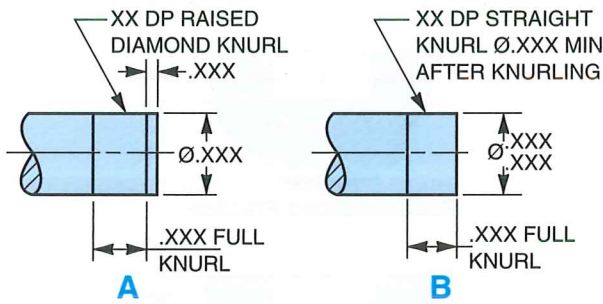
*Knurls* are straight-line or diagonal-line (diamond-shaped) serrations on a part used to provide a better grip or interference fit. Knurls are specified by diameter, along with the type and pitch of the knurl, **Figure 9-22A**. When control of the diameter of a knurl is required for an interference fit between parts, this is also specified, **Figure 9-22B**. The length along the axis may be specified if required.

### Angular Dimensions

Angular dimensions may be specified in degrees or in degrees (°), minutes (′), and seconds (″),



**Figure 9-21.** In a partial section view, a hidden line may be dimensioned to if there is no other way to describe the part. This is an exception to the general rule of avoiding dimensions to hidden lines and should be used infrequently.



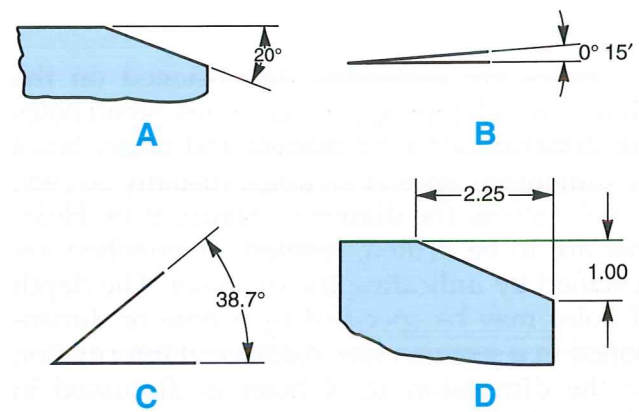
**Figure 9-22.** Knurls are usually explained with a combination of a note and location and size dimensions.

**Figure 9-23.** Angles specified in degrees alone have the numerical value followed by the symbol for degrees, **Figure 9-23A**. When an angle is expressed in minutes alone, the number of minutes is preceded by "0°," **Figure 9-23B**. Angles may be specified in degrees and decimal parts of a degree, **Figure 9-23C**. Angles may also be specified by coordinate dimensions, **Figure 9-23D**.

### Chamfers

Chamfers of 45° may be dimensioned by a note, **Figure 9-24A**. All chamfers, other than 45° chamfers, are dimensioned by giving the angle and the measurement along the length of the part, **Figure 9-24B**.

Chamfers should never be dimensioned along their angular surface. Internal chamfers are dimensioned in the same manner except

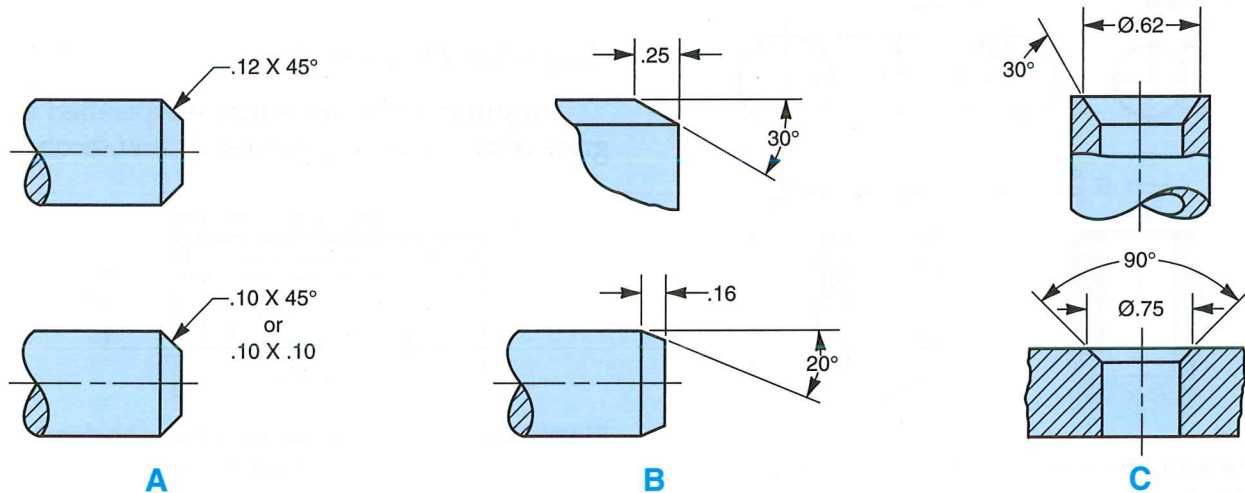


**Figure 9-23.** Accepted methods for placing angular dimensions. Select the most appropriate method for a given instance.

in cases where the diameter requires control, **Figure 9-24C**.

### Counterbored Holes and Spotfaces

A *counterbore* is a recess that allows fillister or socket head screws to be seated below the surface of a part. A *spotface* is similar to a counterbore, except the recess is not as deep. A *spotface* is a machined circular spot on the surface of a part to provide a flat bearing surface for a screw, bolt, nut, washer, or rivet head. A counterbore or spotface is indicated on a drawing by the same symbol, **Figure 9-25A**. The symbol precedes the dimension.



**Figure 9-24.** Accepted methods for dimensioning chamfers. Select the most appropriate method according to the location of the chamfer.



## Countersunk Holes and Depth Dimensions

A *countersink* is a beveled edge (chamfer) cut in a hole to permit a flat head screw to seat flush with the surface. A countersink is indicated by the symbol shown in **Figure 9-25B**. The symbol precedes the dimension.

The depth of a feature is indicated by the depth symbol, also shown in **Figure 9-25B**. The symbol precedes the depth dimension.

## Counterdrilled Holes

A *counterdrill* is the combination of a small recess and a larger recess with a chamfered edge cut

in a hole to allow room for a fastener. Counterdrilled holes are dimensioned by specifying the diameter of the hole and the diameter, depth, and included angle of the counterdrill, **Figure 9-25C**.

## Arc Lengths

The length of an arc measured on a curved outline is indicated by the arc length symbol, **Figure 9-25D**. The symbol is placed above the dimension.

## Dimension Origin Symbol

The origin of a tolerance dimension between two features is indicated with the dimension origin symbol. This symbol is shown in **Figure 9-25E**.

## Square Symbol

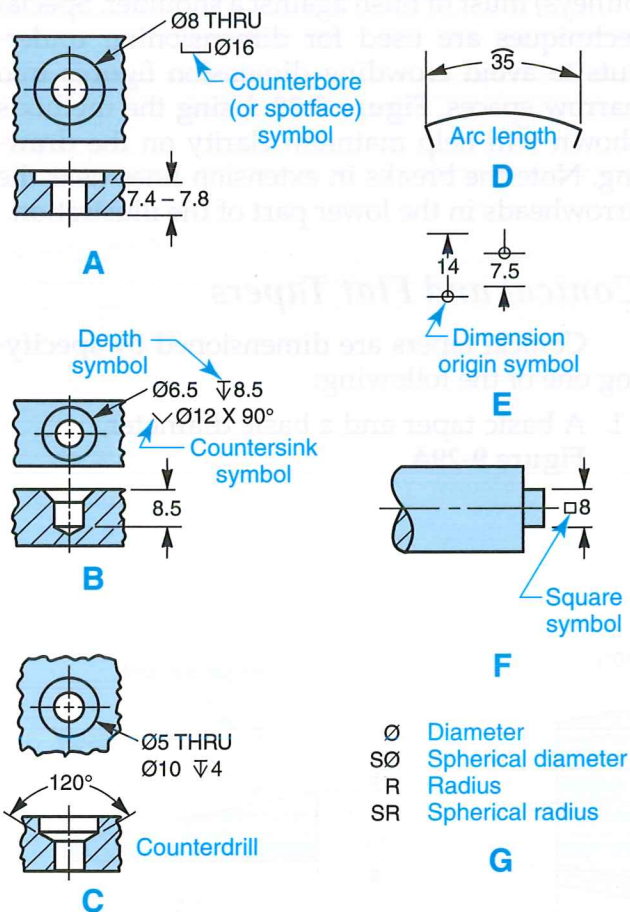
A square-shaped feature is indicated by the square symbol. A single dimension is preceded by the symbol, **Figure 9-25F**.

## Diameter and Radius Symbols

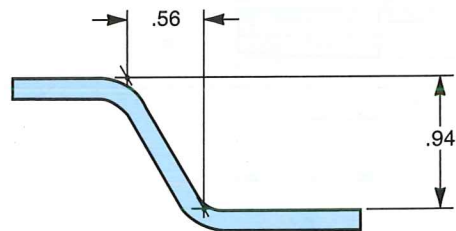
Diameter, spherical diameter, radius, and spherical radius dimensions are indicated by the symbols shown in **Figure 9-25G**. These symbols precede the value of a dimension or tolerance given for a diameter or radius.

## Offsets

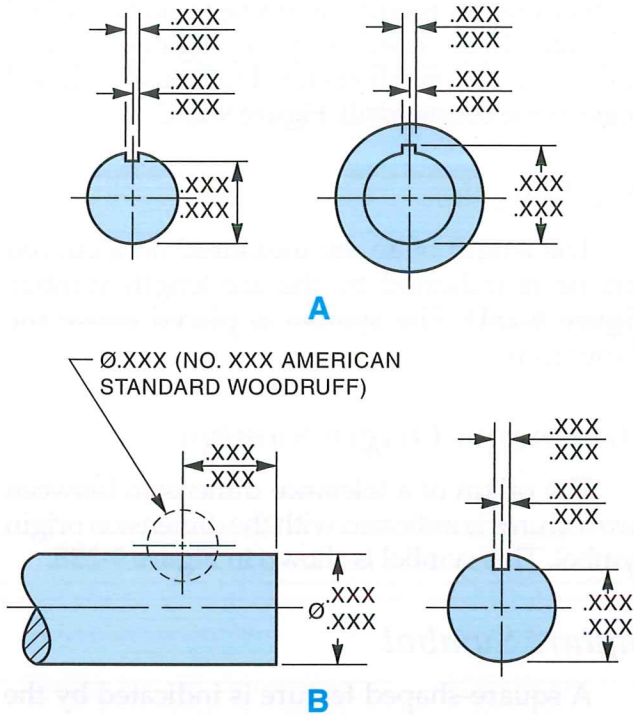
Offsets on a part should be dimensioned from the points of intersection of the tangents. They should be dimensioned along one side of the part, **Figure 9-26**.



**Figure 9-25.** Standard symbols used in dimensioning. A—Counterbores and spotfaces are dimensioned using the same symbol. B—Symbols used for dimensioning a countersink and hole depth. C—Convention used for dimensioning a counterdrill. D—The arc length symbol. E—The dimension origin symbol. F—The square symbol. G—Diameter and radius symbols.



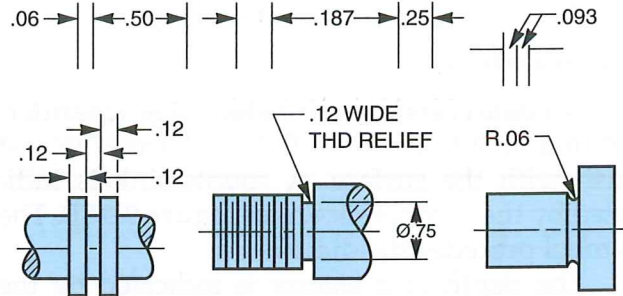
**Figure 9-26.** Offsets should be dimensioned from the points of intersection.



**Figure 9-27.** Dimensioning keyseats. A—Regular keyseats are dimensioned as shown. B—A Woodruff keyseat has a separate convention for dimensioning.

### Keyseats

A *keyseat* is a recess machined in a shaft to fit a key. Regular keyseats are dimensioned as shown in **Figure 9-27A**. Woodruff keyseats are dimensioned as shown in **Figure 9-27B**. For additional information on keys, see the Reference Section.



**Figure 9-28.** Accepted methods for dimensioning undercuts. These methods are useful for dimensioning narrow spaces.

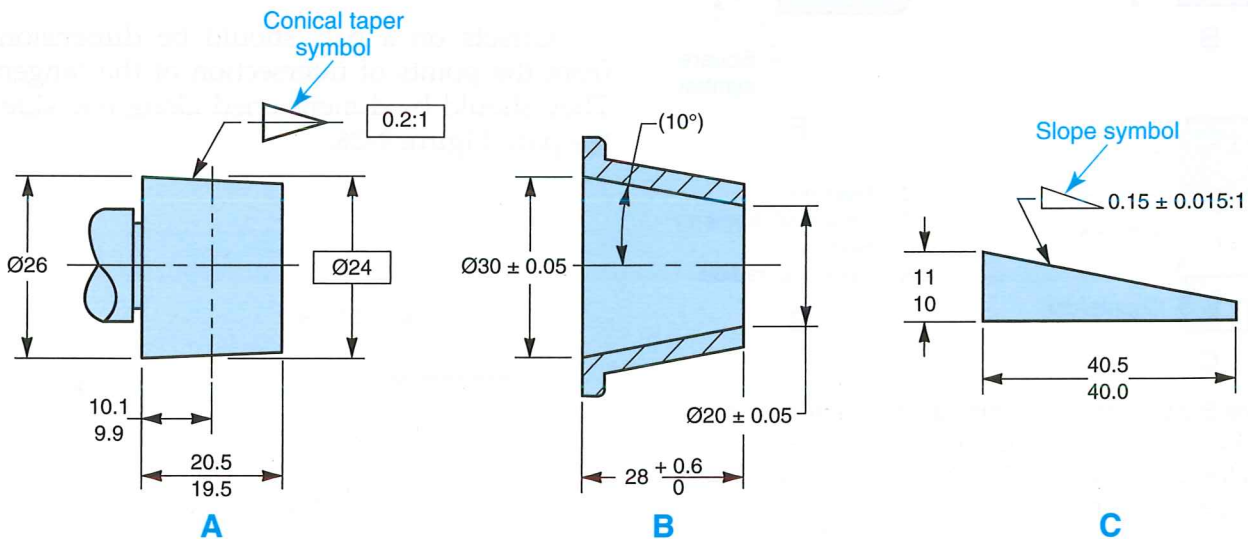
### Undercuts and Narrow Spaces

An *undercut* is a recess at a point where a shaft changes size and mating parts (such as pulleys) must fit flush against a shoulder. Special techniques are used for dimensioning undercuts to avoid crowding dimension figures into narrow spaces, **Figure 9-28**. Using the methods shown will help maintain clarity on the drawing. Note the breaks in extension lines near the arrowheads in the lower part of the illustration.

### Conical and Flat Tapers

Conical tapers are dimensioned by specifying one of the following:

1. A basic taper and a basic diameter, **Figure 9-29A**.



**Figure 9-29.** Accepted methods for dimensioning tapers. Select the most appropriate method for a given application.



2. A size tolerance combined with a profile of a surface tolerance applied to the taper.
3. A tolerance diameter at both ends of a taper and a tolerance length, **Figure 9-29B**.

Flat tapers are dimensioned by specifying a tolerance slope and a tolerance height at one end, **Figure 9-29C**. Taper and slope for conical and flat tapers are identified by the symbols shown in **Figure 9-29**. The vertical leg of the symbol is always to the left.

### Irregular Curves

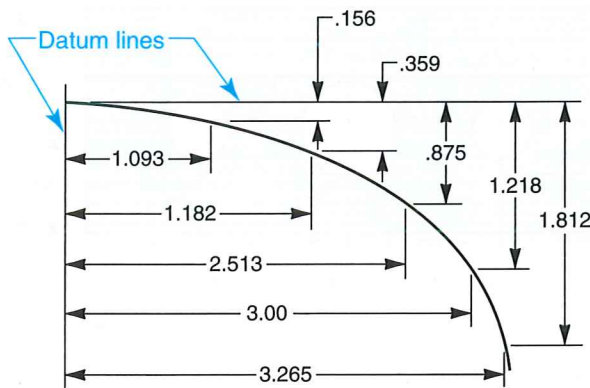
Irregular curves are dimensioned by using coordinate dimensions, **Figure 9-30**. In coordinate dimensioning, each dimension line is extended to a datum line. Coordinate dimensioning is discussed in greater detail later in this chapter.

### Symmetrical Curves

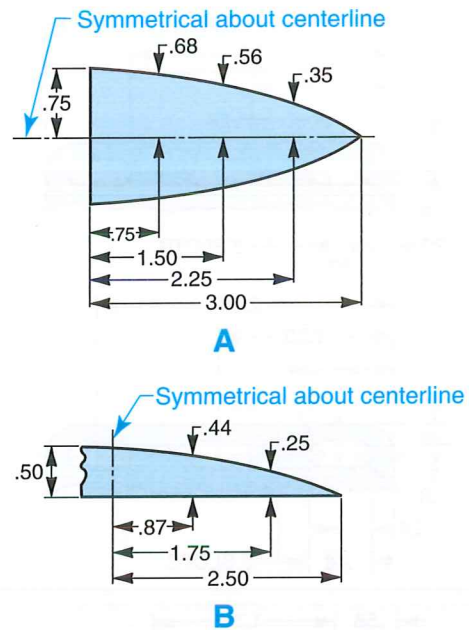
Curves that are symmetrical should be dimensioned on one side of the axis of symmetry only, **Figure 9-31A**. When only one-half of a symmetrical part is shown, it is dimensioned as shown in **Figure 9-31B**.

### Rounded Ends

For parts having fully rounded ends, overall dimensions should be given for the part and the radius of the end indicated but not dimensioned, **Figure 9-32A**. Parts having partially rounded ends should have the radii dimensioned, **Figure 9-32B**.



**Figure 9-30.** Irregular curves should be dimensioned using coordinate dimensions.



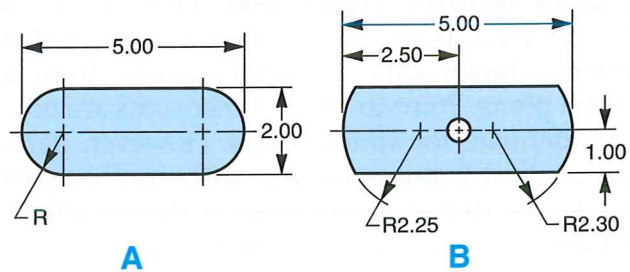
**Figure 9-31.** Curves that are symmetrical to a centerline should be dimensioned on one side of the axis of symmetry only.

### Slotted Holes

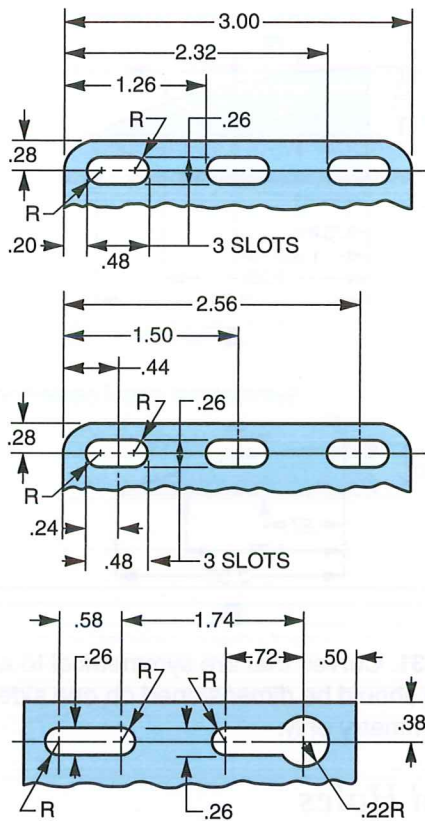
Slotted holes are treated as two partial holes separated by a space. A slot of regular shape is dimensioned for size by length and width dimensions, **Figure 9-33**. The slot is located on the part by a dimension to its longitudinal center and either one end or a centerline.

## Dimensioning Features for Location

*Location dimensions* specify the location or distance relationship of one feature of a part with



**Figure 9-32.** Accepted methods for dimensioning rounded ends. A—For parts with fully rounded ends, the radius of the ends is indicated but not dimensioned. B—For parts with partially rounded ends, the radii are dimensioned.



**Figure 9-33.** Accepted methods for dimensioning slotted holes. Select the most appropriate method for a given application.

respect to another feature or datum. Features may be located with respect to one another by either linear or angular expressions.

### Point-to-Point Dimensioning

In *point-to-point dimensioning*, dimensions are placed in a “chain” from point to point to locate features, **Figure 9-34**. This system is also referred to as *chain dimensioning*. In this system, dimensions do not originate from a datum plane. Point-to-point dimensions are usually adequate for simple parts. However, parts that contain features mating with another part should be dimensioned from a datum plane. Datums are used in coordinate dimensioning (discussed in the next section). In point-to-point dimensioning, one dimension is omitted to avoid locating a feature from more than one point and possibly causing unsatisfactory mating of parts.

### Coordinate Dimensioning

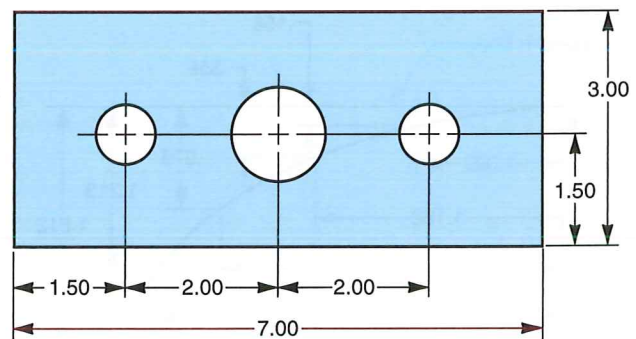
*Coordinate dimensioning* is a type of dimensioning useful in locating holes and other features on parts. Basically, there are two different systems in this type of dimensioning: rectangular coordinate dimensioning and polar coordinate dimensioning. Both systems make use of *datum dimensioning*. In datum dimensioning, all dimensions are from two or three mutually perpendicular datum planes.

*Rectangular coordinate dimensioning* is useful in locating holes and other features that lie in a rectangular or noncircular pattern, **Figure 9-35A**. In this system, dimensions are at right angles to each other and originate from datum planes. The dimensions may also originate from common origins such as centerlines. Holes distributed around a bolt circle can be located accurately using the rectangular coordinate dimensioning system, **Figure 9-35B**.

Rectangular coordinate dimensioning is commonly used in mechanical drafting and manufacturing applications because it provides a way to locate features accurately. This system is used to dimension drawings of parts manufactured in CNC machining.

*Polar coordinate dimensioning* should be used when holes or other features to be located lie in a circular or radial pattern, **Figure 9-36**. A radial (linear) dimension and angular dimensions originating from datum planes are given.

When it is necessary to hold closer tolerances for mating features, true-position dimensioning should be used. This is discussed in Chapter 16.



**Figure 9-34.** Point-to-point dimensions are placed in a “chain” from point to point to locate features.



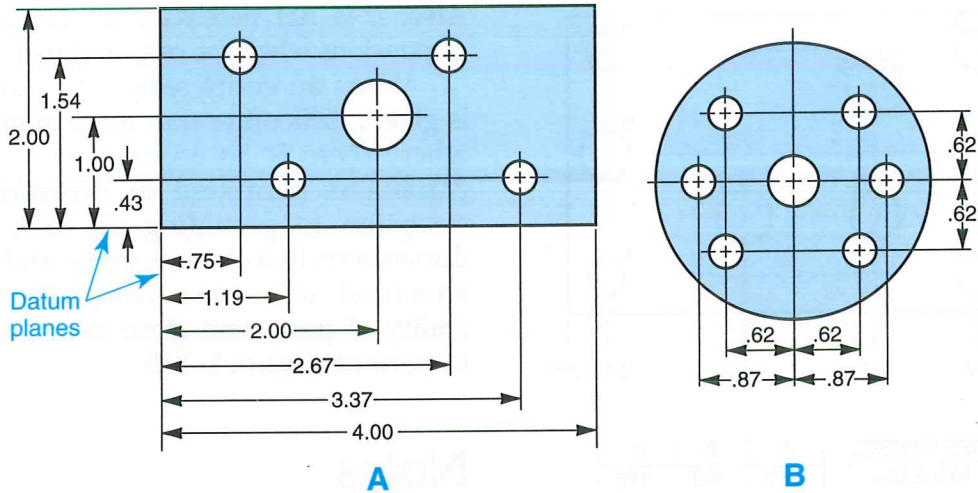


Figure 9-35. Rectangular coordinate dimensioning.

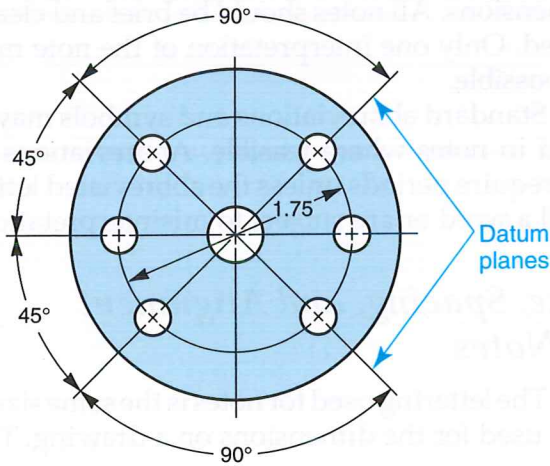


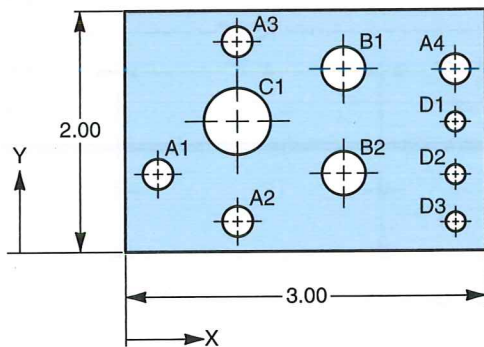
Figure 9-36. A radial (linear) dimension and angular dimensions originating from a datum plane are used in polar coordinate dimensioning.

### Tabular Dimensioning

Tabular dimensioning is a form of rectangular coordinate dimensioning. The location of dimensions for features are given from datum planes and listed in a table on the drawing, Figure 9-37. Dimensions are not all applied directly to the views. This method of dimensioning is useful when a large number of similar features is to be located.

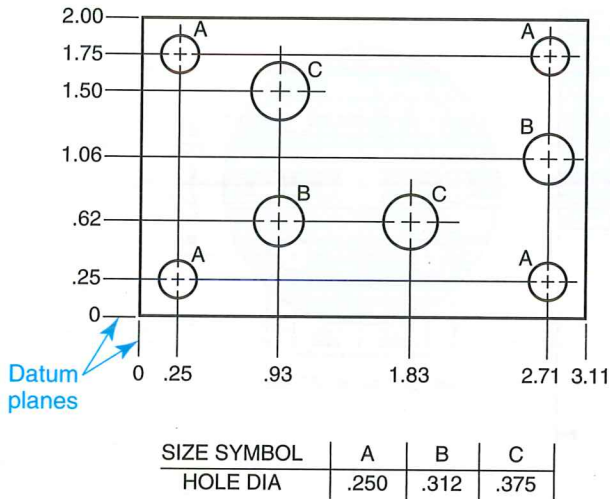
### Ordinate Dimensioning

Ordinate dimensioning is very similar to rectangular coordinate dimensioning. It makes use of datum dimensioning. However, ordinate dimensioning differs from coordinate dimensioning in that the datum planes are indicated as



		REQD	4	2	1	3
		HOLE DIA	.250	.312	.500	.125
POSITION		HOLE SYMBOL				
X →	Y ↑	A	B	C	D	
.250	.625	A1				
1.000	.250	A2				
1.000	1.750	A3				
2.750	1.500	A4				
1.750	1.500		B1			
1.750	.625		B2			
1.000	1.000			C1		
2.750	1.000				D1	
2.750	.625				D2	
2.750	.250				D3	

Figure 9-37. In tabular dimensioning, location dimensions on a drawing are referenced in a table listing.

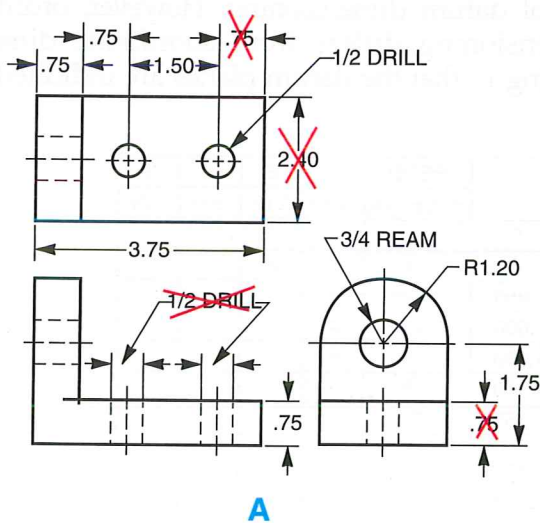


**Figure 9-38.** In ordinate dimensioning, distances are measured from zero coordinates (0,0).

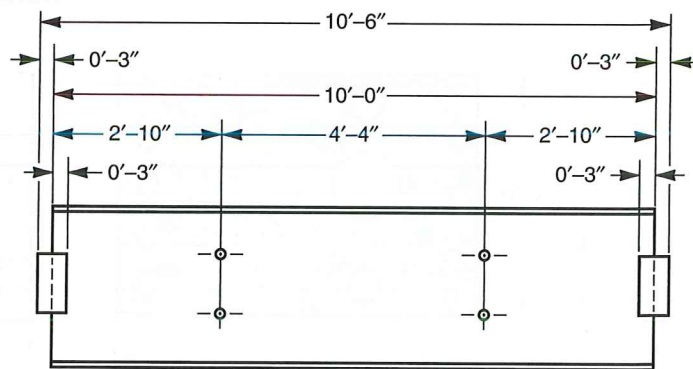
zero coordinates. Dimensions from these planes are shown on extension lines without the use of dimension lines or arrowheads, **Figure 9-38**. This system of dimensioning is sometimes referred to as *arrowless dimensioning*.

## Unnecessary Dimensions

Any dimension not needed in the manufacture or assembly of an item is an unnecessary dimension. This includes dimensions repeated on the same view or on another view, **Figure 9-39A**.



**A**



**B**

**Figure 9-39.** Unnecessary dimensions are omitted from drawings. A—Duplicate dimensions should be eliminated to reduce “clutter” on a drawing. B—On architectural and structural drawings, where tolerances are not as important, the last dimension in a “chain” can be left in.

Also, it is not necessary to include all “chain” dimensions when the overall dimension is given.

When an entire series of chain dimensions is given, difficulties may arise in manufacturing where there is an accumulation of *tolerances* (variations permitted in measurements). The exception to providing all of the individual dimensions in a chain is in the architectural and structural industries, where the interchangeability of parts and close tolerances are not as important, **Figure 9-39B**.

## Notes

Notes are used on drawings to supplement graphic information and dimensions. In some cases, notes are used to eliminate repetitive dimensions. All notes should be brief and clearly stated. Only one interpretation of the note must be possible.

Standard abbreviations and symbols may be used in notes where feasible. Abbreviations do not require periods unless the abbreviated letters spell a word or are subject to misinterpretation.

### Size, Spacing, and Alignment of Notes

The lettering used for notes is the same size as that used for the dimensions on a drawing. This



size is usually .125" in height. Spacing between lines within a note should be from one-half to one full letter height. At least two letter heights should be allowed between separate notes.

All notes should be placed on the drawing parallel to the bottom of the drawing. Lines of a single note, and successive notes in a list of general notes, should be aligned on the left side. Notes related to specific features should also be placed parallel to the bottom of the drawing.

### General Notes

Notes that convey information applying to the entire drawing are called *general notes*. Some examples include the following:

1. CORNER RADII .12 +/- .06
2. REMOVE ALL BURRS AND BREAK ALL SHARP EDGES .01 OR MAX
3. ALL MARKINGS TO BE PER MIL—STD—130B FOR LIQUID OXYGEN SERVICE
4. MAGNETIC INSPECT PER MIL—STD—1-6868

No period is required at the end of the note, unless more than one statement is included within any one note.

General notes are usually placed on the right-hand side of the drawing above the title block or to the left of the title block, **Figure 9-40A**. They are numbered from the top down or from the bottom up, depending on company or industry standards.

Notes are sometimes included in the title block of the drawing, such as general tolerances, material specification, and heat treatment specification, **Figure 9-40B**.

### Local Notes

*Local notes* provide specific information, such as a machine process, **Figure 9-40C**. An actual dimension may also be designated by a local note. Designating a standard part is another example of a use for local notes. For example, a standard size hexagonal cap screw may be designated by the note No. 6-32UNC-2B HEX CAP SCR.

Some examples of local notes include the following:

1. .344 +/- .002, 36 HOLES

2. R.06—2 PLACES
3. PAINTED AREA 1.75 SQUARE AS INDICATED, ONE SIDE ONLY

Local notes are usually located close to a specific feature. A leader usually extends from either the first or the final word of the note. Refer to **Figure 9-40**.

Local notes may be included with the list of general notes, **Figure 9-41**. They refer to a specific feature or area on the drawing. In this case, a reference number is enclosed in a square or triangle called a *flag*. The flag is placed on the drawing near the feature being described. A leader is used to indicate the exact feature being referred to.

To avoid a crowded appearance, or the necessity to relocate a note, notes should not be placed on the drawing until after the dimensions have been added.

## Rules for Good Dimensioning

The ability to draw dimensions properly and accurately is essential in drafting. The following rules should serve as guides to good dimensioning practices:

1. Take time to plan the location of dimension lines. Avoid crowding by providing adequate room for spacing (at least .40" (10 mm) for the first line and .25" (6 mm) for successive lines).
2. Dimension lines should be thin and should contrast noticeably with object lines on the drawing.
3. Dimension each feature in the view that most completely shows the characteristic contour of that feature.
4. Dimensions should be placed between the views to which they relate and outside the outline of the part.
5. Extension lines are gapped away from the object approximately .06 inch (1.5 mm) and extend beyond the dimension line approximately .125 inch (3 mm). Extension lines may cross other extension lines or object lines when necessary. Avoid crossing dimension lines with extension lines or leaders whenever possible.

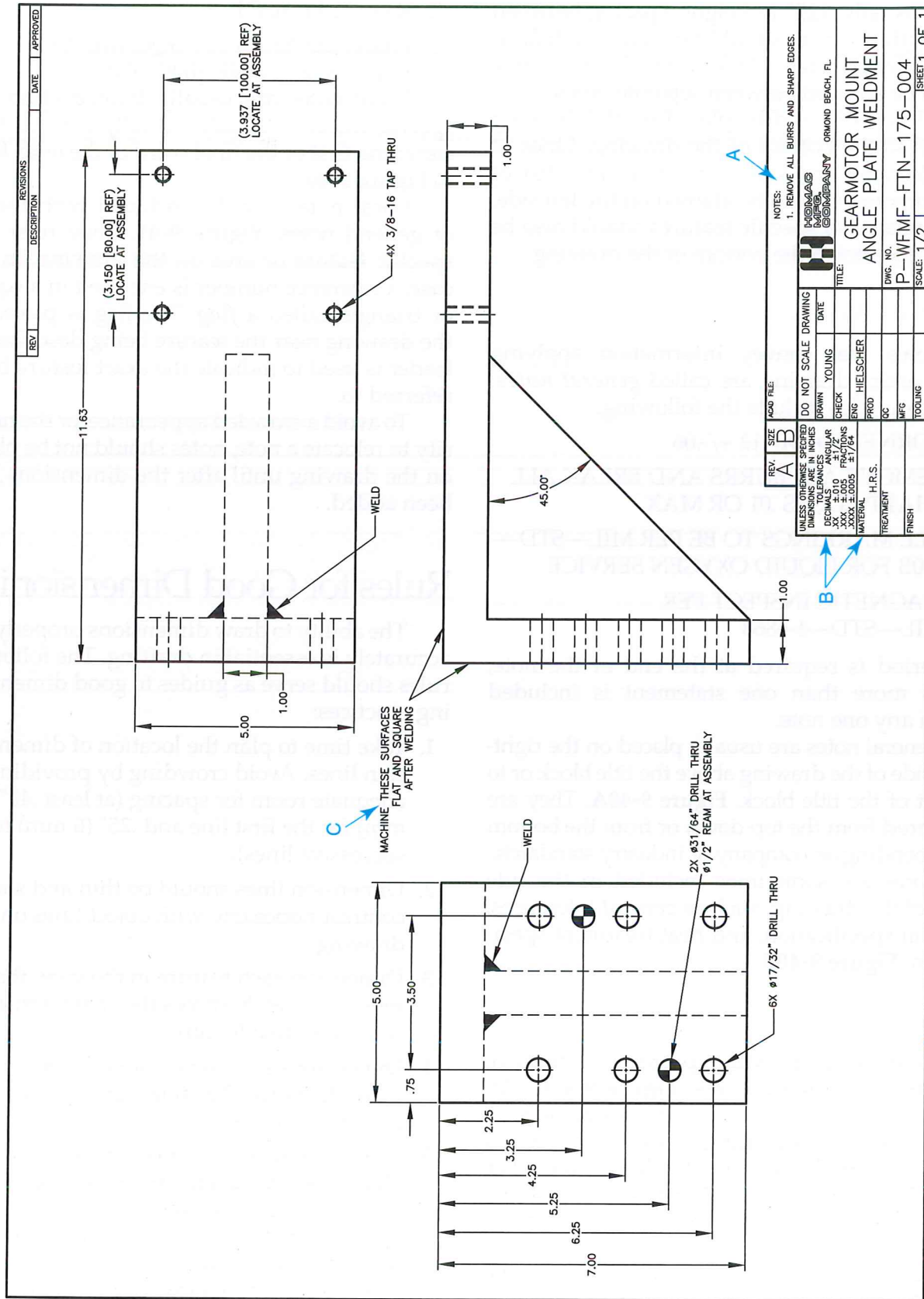
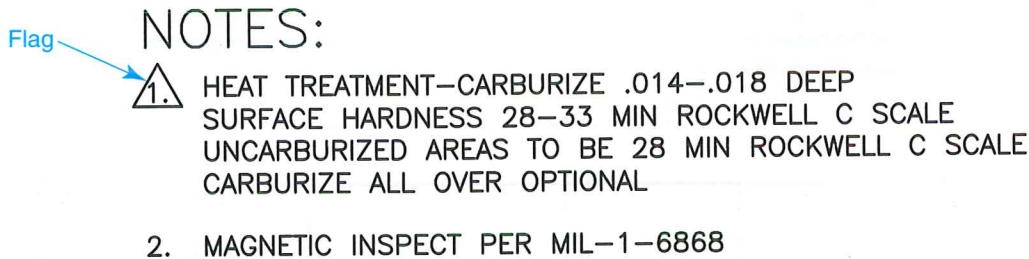


Figure 9-40. Notes are used on a drawing to help clarify details and to communicate information about the part that cannot otherwise be easily communicated. (Autodesk, Inc.)





**Figure 9-41.** Local notes included in general notes can be directed to a feature on the drawing by a reference number and flag.

6. Show dimensions between points, lines, or surfaces that have a necessary and specific relation to each other.
7. Dimensions should be placed on visible outlines rather than hidden lines.
8. State each dimension clearly so that it can be interpreted in only one way.
9. Dimensions must be sufficiently complete for size, form, and location of features so that no calculating or assuming of distances or locations is necessary.
10. Avoid duplication of dimensions. Only dimensions that provide essential information should be shown.
11. In chain dimensioning, one dimension in a dimension chain should be omitted (architectural and structural drawing excepted) to avoid location of a feature from more than one point.

## Dimensioning CAD Drawings

One of the primary benefits of CAD is the speed and consistency with which drawings can be dimensioned. CAD programs typically provide a number of commands and settings to create and control the appearance of dimensions and notes. When these tools are used properly, drawings can be dimensioned at a fraction of the time required to place dimensions manually. It is important to remember that drafting standards for dimensioning apply equally to manual and CAD drafting. The following sections discuss common commands, controls, and methods used to dimension CAD drawings.

## Dimension Styles

A *dimension style* is a set of parameters used to control the appearance of individual dimensioning elements, including dimension lines, arrowheads, and text. See **Figure 9-42**. A dimension style provides a way to manage a comprehensive set of parameters for a particular drafting application. Different dimension styles can be set up to conform to standards for different applications. For example, you can create a mechanical dimension style that uses arrowheads for dimension lines or an architectural dimension style that uses tick marks. Dimension style settings are provided for each type of dimensioning element, and each setting has a default value that can be altered as needed.

Some CAD programs provide special settings called *dimension variables* that allow you to manage the current settings of dimensioning elements. For example, you may be able to change the offset gap for extension lines by accessing the appropriate dimension variable and entering a value. However, in most cases, it is preferable to control dimension settings by using a dimension style based on the standards or requirements of a given application. Dimension styles provide a convenient way to maintain consistency and keep track of the different types of elements used on a drawing. In addition, they serve as a reference for other drafters in cases where drawings are combined with other documentation in a set of drawings.

Dimension styles are normally created using the **Dimstyle** command. Dimension style settings are typically organized into groups for use with similar elements. The different elements and the typical settings available are discussed in the following sections.



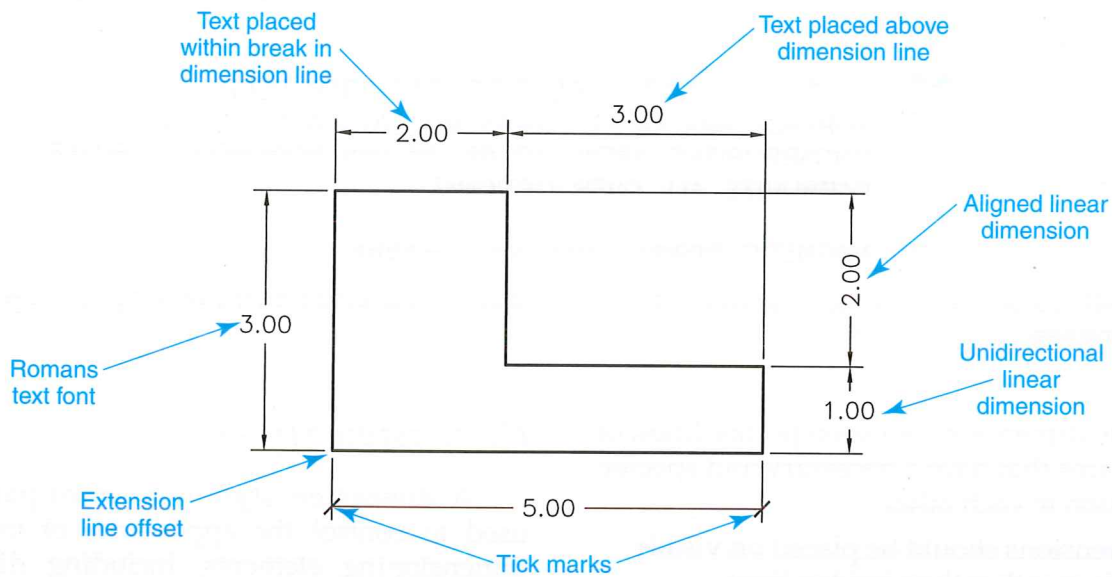


Figure 9-42. The settings of a dimension style control the appearance of the individual dimensioning elements.

## Unit settings

The unit settings in a dimension style determine the unit format and precision used for linear and angular dimensions on the drawing. The available formats for linear dimensions include decimal units, architectural units, fractional units, and other unit types, such as alternate units (used for dual dimensioning). The available formats for angular dimensions include decimal degrees, as well as degrees, minutes, and seconds, and other unit types. The unit precision setting for each dimension type determines the precision of the dimensions (for example, the number of places following the decimal in a decimal dimension).

The dimension style unit settings also include zero suppression settings. These determine whether the leading and trailing zeroes in a given dimension value are *suppressed* (omitted). Separate settings can be made for the leading and trailing figures. As discussed earlier in this chapter, in metric dimensioning, a leading zero before the decimal point is used for values less than one. In inch dimensioning, the leading zero is omitted.

## Dimension and extension line settings

As is the case in manual drafting, dimension and extension lines on CAD drawings should appear consistent throughout the drawing and must conform to standards. Typical dimension style settings for dimension lines include the spacing between adjacent lines (in

datum dimensions) and the extension of lines past extension lines (when using architectural tick marks). Typical settings for extension lines include the offset from the object and the extension of lines past dimension lines. For both types of lines, you can also set the display color and specify whether to suppress the display of one or both lines. Suppressing the display of a line may be required when the line is duplicated or a special practice must be followed.

## Arrowhead and symbol settings

CAD programs typically provide a number of arrowhead styles to use for terminating dimension lines and leader lines. These include filled and unfilled arrowheads, tick marks, and dots. A separate setting is used to control the size of the symbol.

Other settings are available for other drafting symbols, including center marks, arc length symbols, and radius jog symbols. When placing a radius dimension, center marks can be generated as small center marks, centerlines, or both by making the appropriate setting. The size setting determines the size of the symbol. An arc length symbol is drawn when dimensioning the length of an arc. The symbol can be set to display above or in front of the dimension figure. Radius jog symbols are used when dimensioning foreshortened radii. An angle setting is available for controlling the angle of the radius dimension line.



## Text settings

The text settings in a dimension style determine the text style, height, color, placement, and alignment of the dimension text. The dimension text style can be set to use the same style assigned to other text on the drawing (for example, a style that uses the Romans text font). As discussed earlier in this chapter, the dimension text height should be the same height used for other text on the drawing. As is the case with dimension lines and extension lines, a display color can be set for the dimension text.

The text placement settings determine whether the text for horizontal dimensions is placed within a break in the dimension line or above the dimension line. For vertical dimensions, the text can be placed within a break in the dimension line or to the right or left of the dimension line.

The text alignment settings determine whether the text remains horizontal (as in unidirectional dimensioning) or aligns with the direction of the dimension line (as in aligned dimensioning). As previously discussed, unidirectional dimensioning is the standard in mechanical drafting. Aligned dimensioning is typically used in architectural drafting.

## Fit and scale settings

On drawings where space is limited, or in cases where it is difficult to fit all of the dimensioning elements within the extension lines, you may want to specify how the elements are placed within extension lines by the program. The fit settings of a dimension style allow you to identify which elements take precedence when placing dimensions. For example, you can specify to place the text within the extension lines if there is not enough room for all of the dimensioning elements, or you can specify to place the dimension line and arrows only if space is limited. You can also specify to place all of the elements outside the extension lines when space does not allow for all of the elements to fit within the extension lines. Several other options are also available.

The dimension scale can be set to control the size of all dimensioning elements, including text height and arrow sizes. This value is normally set to the scale of the drawing.

## Dimensioning Commands

*Dimensioning commands* allow you to automatically place dimensions on a drawing. In manual drawing, dimension lines are laid out by hand and measurements are made using drafting instruments. With CAD-generated dimensioning, the drafter simply picks several points. The program then calculates and places the dimension and adds the proper dimension lines and extension lines (or leader lines). The drafter is prompted whether to accept or alter the dimension text, which allows changes to be made before the dimension is placed on the drawing.

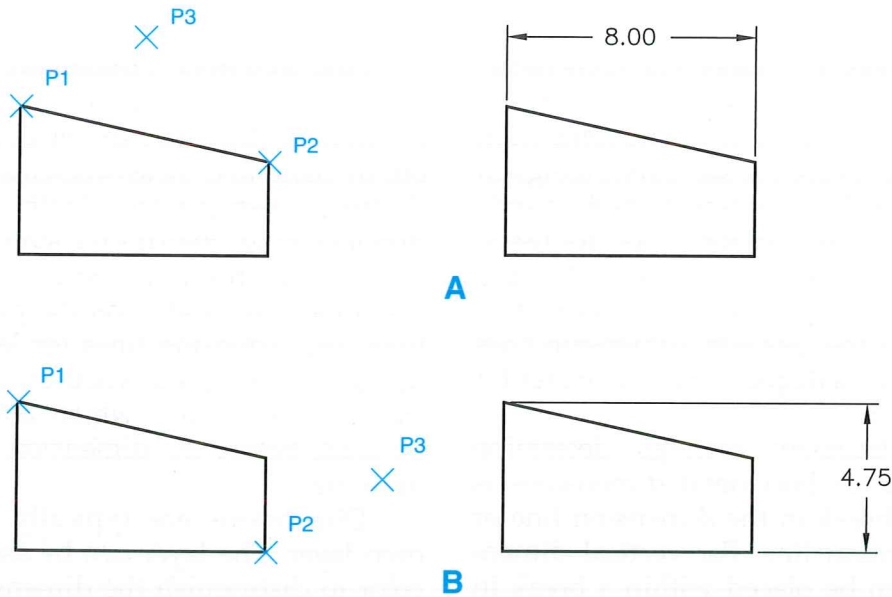
Dimensions are typically placed on their own layer. The layer can be assigned a unique color to distinguish the dimensions from other objects. Also, as previously discussed, one or more dimension styles are normally created for use with dimensioning commands.

There are five basic methods used to dimension CAD drawings. These include linear, angular, radial (diameter and radius), leader, and ordinate dimensioning. Different commands are used for each method.

### Linear dimensioning

*Linear dimensions* are used to dimension straight distances. They can be used to draw horizontal, vertical, and aligned dimensions. The **Linear** dimensioning command is typically used to draw linear dimensions, **Figure 9-43**. To place a linear dimension with this command, pick two points using object snaps or select two lines that establish the extension line origins. The program then prompts you for the placement of the dimension line. Select the desired placement. Before picking a point on screen, you can enter the **Text** option to alter the dimension text as needed. This is useful for creating local notes or dimensions requiring special symbols. When you pick a location for the dimension line, the dimension line, extension lines, and dimension text are placed automatically.

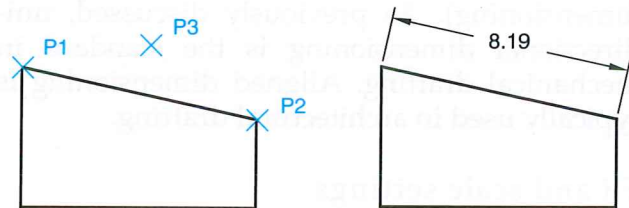
The **Linear** dimensioning command can also be used to draw aligned dimensions by creating a dimension style that aligns the text with the dimension line. This method can be used in architectural drafting. Another common way to draw aligned linear dimensions is to use the



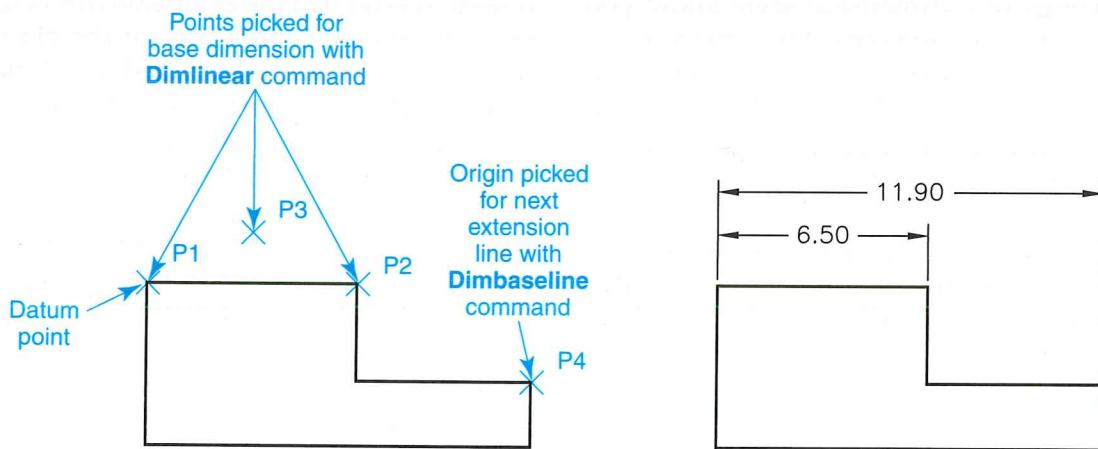
**Figure 9-43.** Linear dimensions are created with the **Linear** dimensioning command. A—Placing horizontal dimensions. B—Placing vertical dimensions.

**Aligned** dimensioning command. This command orients the dimension line parallel to the surface being dimensioned, **Figure 9-44**. This method is useful for dimensioning angled features.

There are also linear dimensioning commands for creating datum dimensions and chain dimensions. Datum dimensions are sometimes referred to as *baseline* dimensions, and chain dimensions are sometimes referred to as *continued* dimensions. The **Baseline** dimensioning command is typically used to draw datum dimensions, **Figure 9-45**. This command requires you to pick

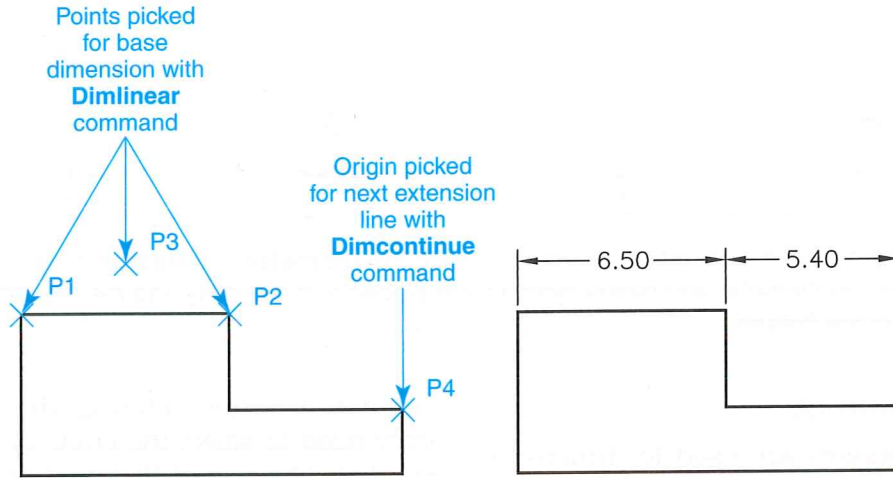


**Figure 9-44.** Aligned linear dimensions can be created with the **Aligned** dimensioning command.



**Figure 9-45.** Datum dimensions can be created with the **Baseline** dimensioning command. A base dimension is used to establish the datum point. The next dimension is drawn automatically by selecting an extension line origin.





**Figure 9-46.** Chain dimensions can be created with the **Continue** dimensioning command. A base dimension is used to establish the first dimension in the chain. The next dimension is drawn automatically by selecting an extension line origin.

a series of locations for extension lines in relation to a base dimension. The base dimension that you pick establishes the datum origin. When you pick the next origin for an extension line, the elements making up the datum dimension are drawn automatically. You can draw datum dimensions as linear, angular, or ordinate dimensions.

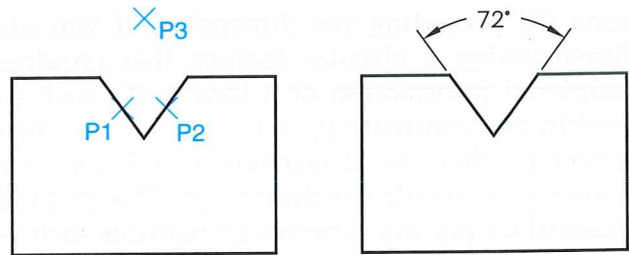
Chain dimensions are typically drawn using the **Continue** dimensioning command, **Figure 9-46**. First, select a base dimension. Then, select additional points for extension lines. The elements making up the chain dimensions are drawn automatically. You can draw chain dimensions as linear, angular, or ordinate dimensions.

### Angular dimensioning

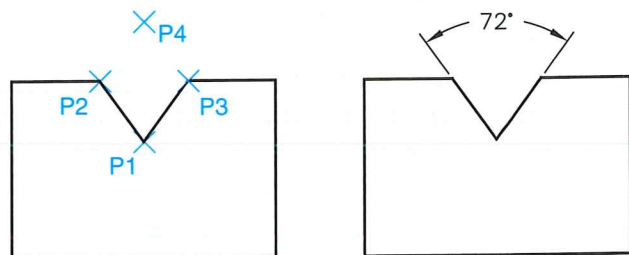
**Angular dimensions** define the angle between two nonparallel lines. The **Angular** dimensioning command is normally used to draw angular dimensions. You can dimension the angle between two lines, the included angle of an arc, or a segment of a circle. To dimension an angle between two lines with the **Angular** command, you can select the two lines forming the angle or three points that define the vertex and the angle. To use the first method, select the two lines that form the angle and then pick the location of the dimension line, **Figure 9-47**. To use the second method, pick the angle vertex and then pick the two points that form the angle. Then, pick the dimension line location, **Figure 9-48**. The vertex might be a corner, the intersection of two lines, or

some other point. The two endpoints might be the endpoints of two intersecting lines.

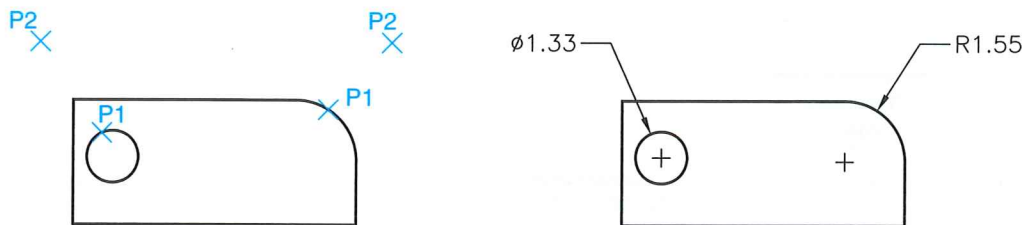
Angular dimensions can be used with linear dimensions to dimension chamfers as discussed earlier in this chapter. For dimensions that require additional text (such as local notes), you can use the **Text** option to enter the text. The **Angular** command can also be used to draw polar coordinate dimensions.



**Figure 9-47.** Using the **Angular** dimensioning command to dimension the angle between two lines.



**Figure 9-48.** Using the **Angular** dimensioning command to dimension an angle formed by a vertex and two endpoints.



**Figure 9-49.** Drawing diameter and radius dimensions using the **Diameter** and **Radius** dimensioning commands. Note that the diameter and radius symbols are placed automatically and the resulting leader line points to the center of the feature.

## Radial dimensioning

**Radial dimensions** are used to dimension circular objects. As discussed earlier in this chapter, radius dimensions are used for arcs. Diameter dimensions are used for circles. The **Radius** dimensioning command is typically used to dimension arcs, and the **Diameter** dimensioning command is typically used to dimension circles. The two commands function in a similar manner and are simple to use. After entering the command, pick the circle or arc to dimension. When you pick a location for the dimension, a leader line and dimension value are placed automatically, **Figure 9-49**. The leader points to the center of the feature, which is standard practice.

Most programs add the proper symbol for diameter dimensions ( $\varnothing$ ) and radius dimensions (R) preceding the dimension. If you are dimensioning a circular feature that requires additional information or a local note, such as machining information, you can use the **Text** option to alter the dimension text before the value is placed with the dimension. This method is useful for placing symbols for features such as counterbored and countersunk holes.

Diameter and radius dimensions can be drawn with the text inside or outside the feature, depending on the size of the feature and where you locate the dimension text. In addition, for radius dimensions, you can force a dimension line to be drawn inside the arc extending from the center. This is accomplished by using a dimension style with the appropriate setting.

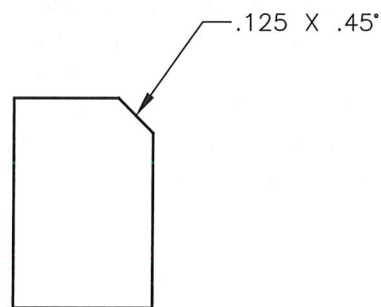
Center marks or centerlines are normally placed automatically by the program when drawing diameter and radius dimensions. When required, center marks and centerlines can also be drawn without placing a dimension by using a command such as the **Center** dimensioning

command. After entering the command, you only need to select the circle or arc to place the symbol. The size of the symbol is controlled by the dimension style setting.

Other special commands may be available for dimensioning radial features such as foreshortened radii and arc lengths. When placing a foreshortened radius dimension, a special radius jog symbol is used. After entering the appropriate command, the arc or circle is selected, followed by a center point, dimension line, and symbol location. When dimensioning the length of an arc, the arc is selected, followed by a location for the dimension.

## Leader dimensioning

**Leader dimensions** are used to place notes. Most CAD programs provide a **Leader** command to draw leader lines connected to notes. After entering the command, pick two points. The first point specifies the feature to which the leader note applies. The second point specifies the location of the note. After picking the two points, enter the note text. The leader, arrowhead, and note are added to the drawing, **Figure 9-50**.



**Figure 9-50.** Using the **Leader** command to place a note for a chamfer.



As shown in **Figure 9-50**, the **Leader** command is useful for dimensioning chamfers. The **Leader** command can also be used for creating feature control frames used in geometric dimensioning and tolerancing applications. This is discussed in Chapter 19.

## Ordinate dimensioning

As previously discussed, ordinate dimensions are similar to linear dimensions. They originate from datum planes and are used to specify linear distances. However, they are shown as extension lines without dimension lines and arrowheads. Ordinate dimensions can typically be drawn using the **Ordinate** dimensioning command. When using this command, you are prompted for an extension line origin and an extension line endpoint. Each extension line you draw measures a dimension from a datum origin (for example, the corner of an object). The datum origin establishes zero coordinates (0,0). Before drawing ordinate dimensions, you may want to relocate the origin of the current user coordinate system to the datum origin to establish zero coordinates.

## Creating Notes

Local notes typically refer to specific features and are attached to leader lines. For this reason, they are normally created with the **Leader** command. General notes that apply to the entire drawing can be created by using text commands. Common methods for creating text are discussed in Chapter 5. General notes can be placed within or next to the title block. They should use the same font and height as the dimensions on the drawing. They can be placed on their own layer or the same layer used by dimensions. As is the case with dimensions, notes should have a consistent appearance and should be clearly stated. When required, standard drafting symbols and abbreviations should be used to convey the information.

## Chapter Summary

Dimensioning is the process of defining the size, form, and location of geometric components on a drawing. Two general types of dimensions are used on drawings—size and location dimensions.

Dimension lines are thin lines with termination symbols (generally arrowheads). Extension lines are used to indicate the termination of a dimension. Leaders are thin, straight lines that lead from a note or dimension to a feature on the drawing. Dimension figures are numerals that specify the length of the dimension line. Dimension figures are placed in the center of a dimension line where practical.

Linear dimensions on a drawing may be expressed in decimal inch units or common fractions of an inch in the US Customary (English) system of measurement. The metric system uses the millimeter.

Dimensioning consists of describing the size and position of each feature of an object. There are many types of features that are dimensioned in a specific fashion. Some of these include: knurls, angles, chamfers, countersunk holes, arc lengths, diameters and radii, offsets, keyseats, and tapers.

Location dimensions specify the location or distance relationship of one feature of a part with respect to another feature or datum. Point-to-point dimensioning (also called chain dimensioning) is usually adequate for simple parts. Other systems include coordinate dimensioning (used in datum dimensioning), tabular dimensioning, and ordinate dimensioning.

Avoid unnecessary dimensions. For example, it is not necessary to include all chain dimensions when the overall dimension is given.

Notes are used on drawings to supplement graphic information and dimensions. Notes may be used to eliminate repetitive dimensions. Notes may be either general or specific. General notes apply to the entire drawing. Local notes provide specific information about a certain part, operation, etc.



Dimension styles and dimensioning commands are used to create dimensions on CAD drawings. Style settings are used to control the appearance of dimensioning elements. Different commands are available for each dimensioning method. These commands automate the dimensioning process and create accurate dimensions when used properly.

Whether you are dimensioning drawings manually or with CAD, correct dimensioning form is important to ensure clarity. Rules for good dimensioning procedure should be followed when dimensioning a part or object.

## Additional Resources

### Selected Reading

ASME Y14.5M, *Dimensioning and Tolerancing*  
American Society of Mechanical Engineers  
(ASME)  
345 East 47th Street  
New York, NY 10017  
[www.asme.org](http://www.asme.org)

### Review Questions

1. What are the two general types of dimensions used on drawings?
2. The diameter of a cylinder and the width of a slot are examples of \_\_\_\_\_ dimensions.
3. The distance from the edge of a part to the center of a hole is an example of a \_\_\_\_\_ dimension.
4. All lines used in dimensioning are drawn as \_\_\_\_\_ lines.
5. A dimension line is a line with \_\_\_\_\_ symbols at each end (generally arrowheads) to indicate the direction and extent of a dimension.
6. The first dimension line is spaced \_\_\_\_\_ from the view depending on space available on the drawing.
  - A. .125" to .250"
  - B. .250" to .375"
  - C. .375" to 1"
  - D. 1" to 1.25"
7. What are extension lines used to indicate?
8. \_\_\_\_\_ are thin, straight lines that lead from a note or dimension to a feature on the drawing.
9. \_\_\_\_\_ notes serve the same purpose as dimensions.
10. The width of the base of an arrowhead should be \_\_\_\_\_ its length.
11. The height of dimension figures on a drawing is usually \_\_\_\_\_.
  - A. .125"
  - B. .250"
  - C. .375"
  - D. .500"
12. Name the two basic placement systems for orienting dimensions on a drawing.
13. In the metric system of measurement, dimensions are given in \_\_\_\_\_ on most drawings.
14. Name the four basic types of dimensioning systems used in drafting.
15. \_\_\_\_\_ dimensioning is preferred in most manufacturing industries because decimals are easier to add, subtract, multiply, and divide.
16. What type of dimensioning is commonly used on drawings in architectural and structural drafting?
17. Many countries that use the SI Metric system of measurement use a(n) \_\_\_\_\_ for the decimal point in dimension figures.
18. Dual dimensioning uses \_\_\_\_\_ and \_\_\_\_\_ dimensions on the same drawing.
19. \_\_\_\_\_ dimensions describe the size of each feature on a part.
20. Circular arcs are dimensioned by indicating their \_\_\_\_\_.
21. Holes are preferably dimensioned on the view in which they appear as \_\_\_\_\_.
22. What are *knurls*?



23. A(n) \_\_\_\_\_ is a beveled edge (chamfer) cut in a hole to permit a flat head screw to seat flush with the surface.
  - A. counterbore
  - B. countersink
  - C. offset
  - D. spotface
24. A(n) \_\_\_\_\_ is a recess machined in a shaft to fit a key.
25. A(n) \_\_\_\_\_ is a recess at a point where a shaft changes size and mating parts must fit flush against a shoulder.
26. In \_\_\_\_\_ dimensioning, dimensions are placed in a "chain" to locate features.
27. What are the two systems used in coordinate dimensioning?
28. When is tabular dimensioning useful?
29. Variations permitted in measurements are known as \_\_\_\_\_.
30. \_\_\_\_\_ are used on drawings to supplement graphic information and dimensions.
31. The size (height) of notes on a drawing is usually \_\_\_\_\_" in height.
32. All notes should be placed on the drawing \_\_\_\_\_ to the bottom of the drawing.
33. What are *general notes*?
34. In CAD drafting, a dimension \_\_\_\_\_ is a set of parameters used to control the appearance of individual dimensioning elements.
35. \_\_\_\_\_ commands allow you to automatically place dimensions on a CAD drawing.
36. Identify the five basic methods used to dimension CAD drawings.
37. In CAD, local notes are normally created with the \_\_\_\_\_ command.

## Drawing Problems

The following problems are designed to give you practice in dimensioning drawings. Draw the problems as assigned by your instructor. The problems are classified as introductory, intermediate, and advanced. A drawing icon identifies the classification. These problems can be completed manually or using a CAD system.

The given problems include customary inch and metric drawings. Use one A-size or B-size sheet for each problem. Select the proper scale for the sheet size being used.

Center the views and make the best use of space available. Provide ample space between views. The dimensions should not be crowded.

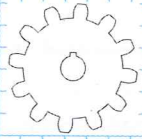
If you are drawing the problems manually, use one of the layout sheet formats given in the Reference Section. If you are using a CAD system, create layers and set up drawing aids as needed. Draw a title block or use a template. Save each problem as a drawing file and save your work frequently.

## Drawing Dimensioning Elements

Study the drawings shown in Problems 1–6. If you are drawing the problems manually, sketch each problem first and have it checked by your instructor. Then, use freehand sketching techniques to draw the required extension lines, dimension lines, and leaders to correctly dimension the drawings. No dimension figures are to be included. Letter the title of each part in the title block of the sketch.

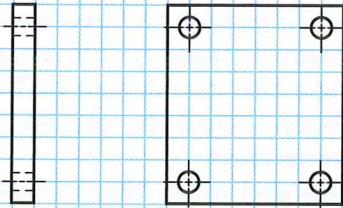
If you are using a CAD system, draw the views for each problem using approximate dimensions. Then, use the appropriate dimensioning methods and commands to dimension each problem. Use the rules for good dimensioning discussed in this chapter.



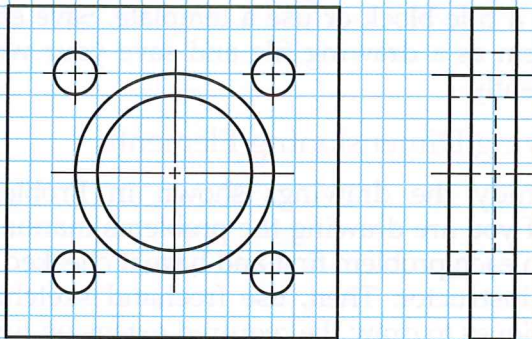


**Introductory**

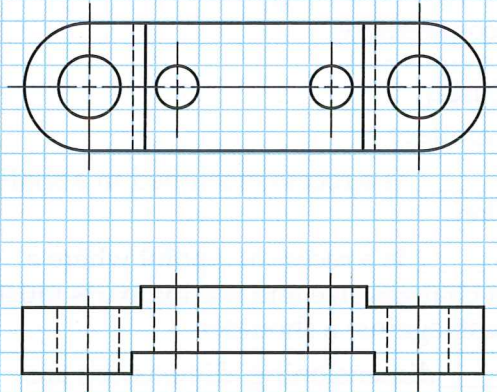
1. Pressure Regulator Plate



2. Bearing Housing

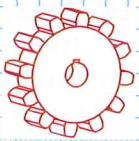
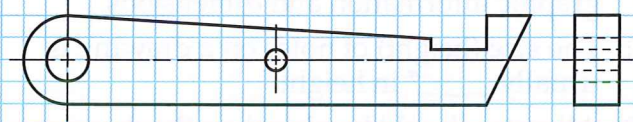


4. Bearing Block



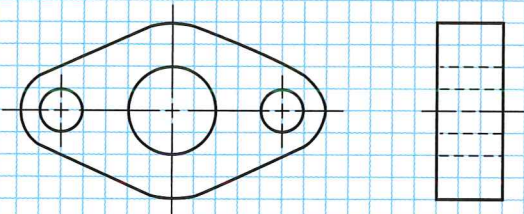
**Advanced**

5. Safety Lock

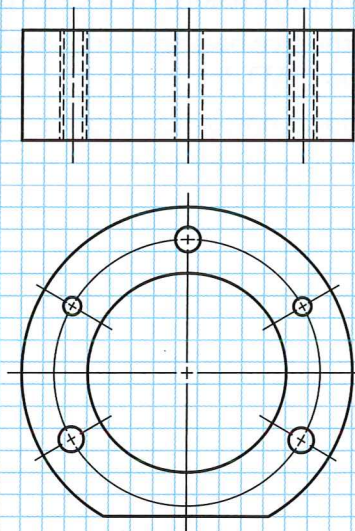


**Intermediate**

3. Water Inlet Flange



6. Shaft Housing

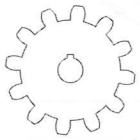




## Drawing and Dimensioning Views

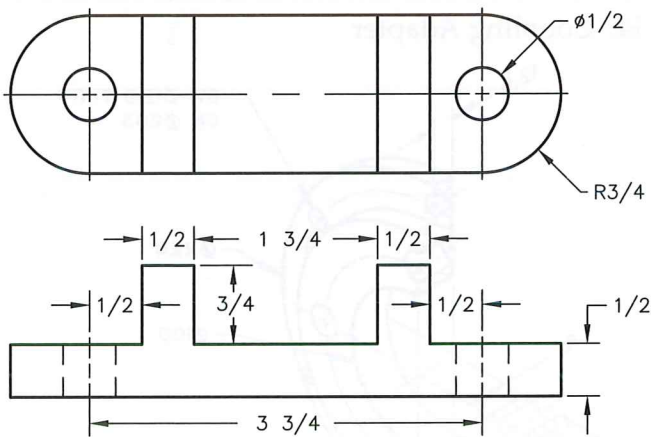
Study the drawings shown in Problems 7 and 8. If you are drawing the problems manually, sketch each problem first and have it checked by your instructor. Then, use proper methods and conventions to dimension the drawings. Use the rules for good dimensioning discussed in this chapter. Letter the title of each part in the title block of the sketch.

If you are using a CAD system, draw the views for each problem. Then, use the appropriate dimensioning methods and commands to dimension each problem.

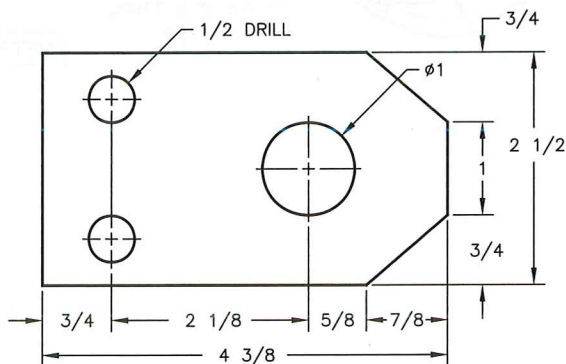


### Introductory

7. Spacer Block



8. Clamp Plate

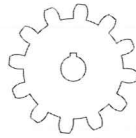


MATERIAL:  $1/4$ " STEEL PLATE

## Drawing and Dimensioning Multiview Drawings

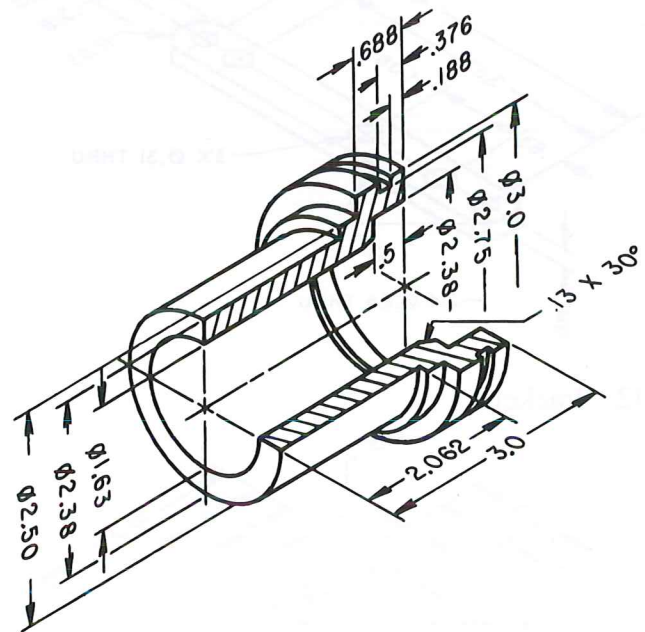
Study the pictorial drawings shown in Problems 9–20. Select and draw the necessary views for each problem. If you are drawing the problems manually, sketch each problem first and have it checked by your instructor. Then, use proper methods and conventions to dimension the drawings. Use the rules for good dimensioning discussed in this chapter. Letter the title of each part in the title block of the sketch.

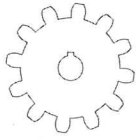
If you are using a CAD system, draw the views for each problem. Then, use the appropriate dimensioning methods and commands to dimension each problem.



### Introductory

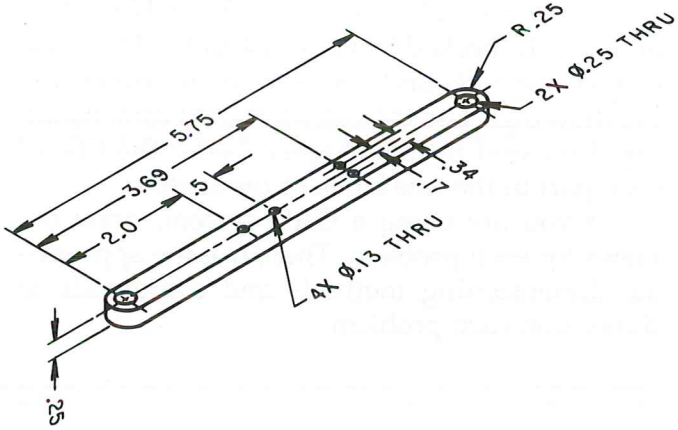
9. Outlet Check Valve



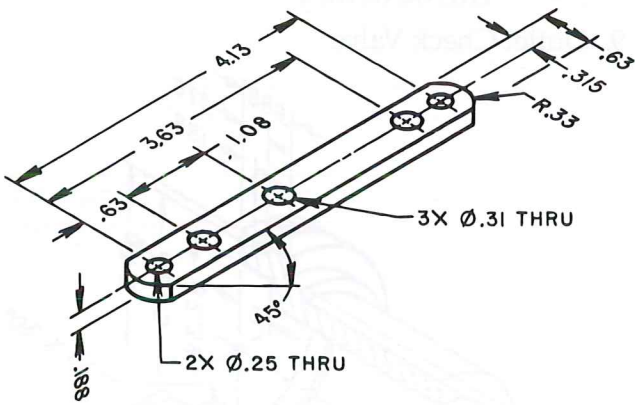


**Introductory**

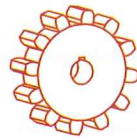
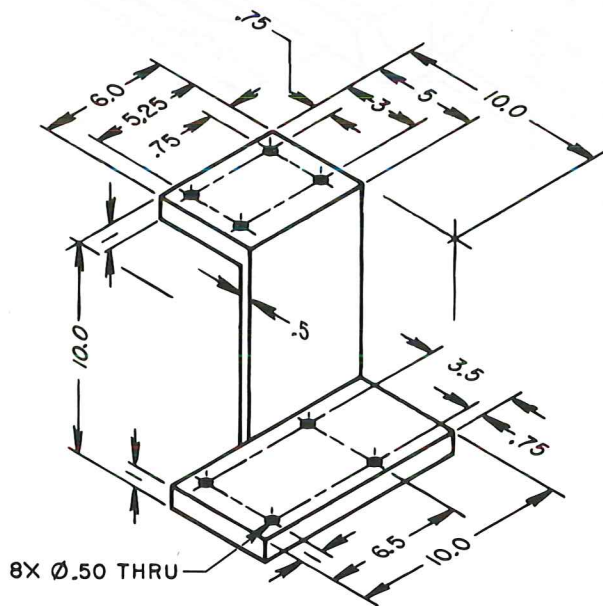
10. Can Opener Handle



11. Throttle Lever Link

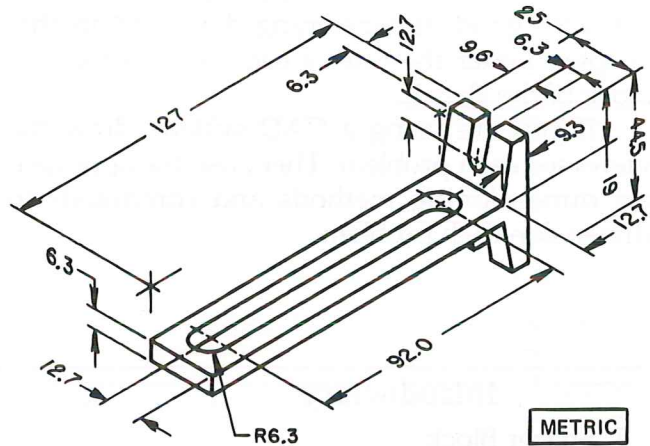


12. Bracket

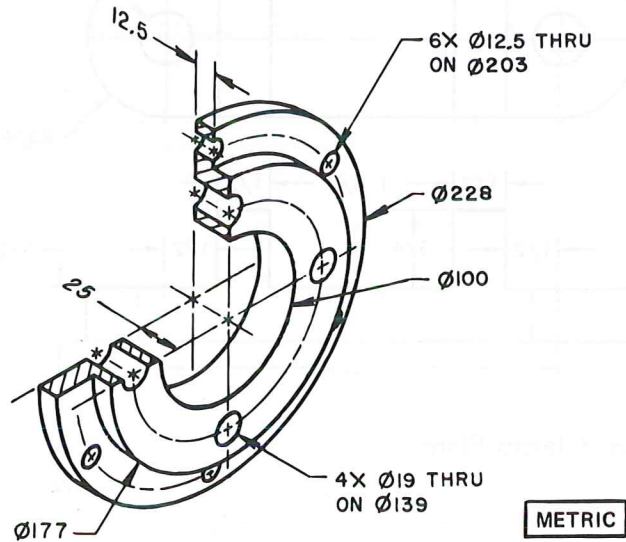


**Intermediate**

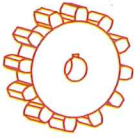
13. Cylinder Rod Guide Bracket



14. Coupling Adapter

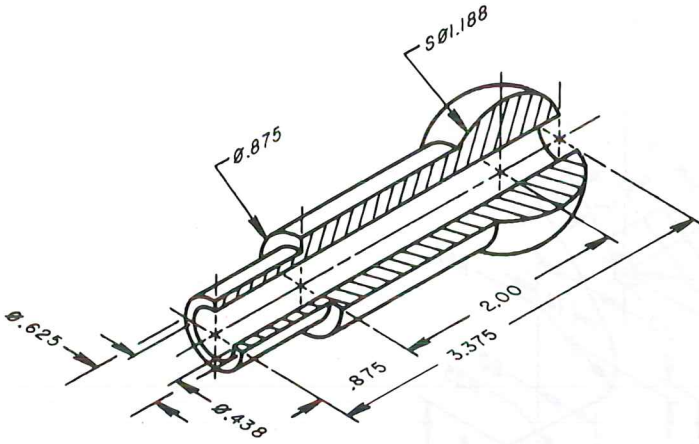




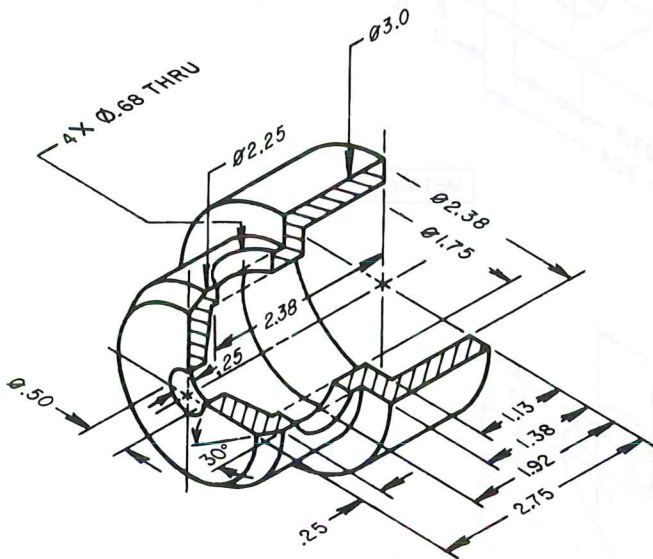


**Intermediate**

15. Connecting Pump Link

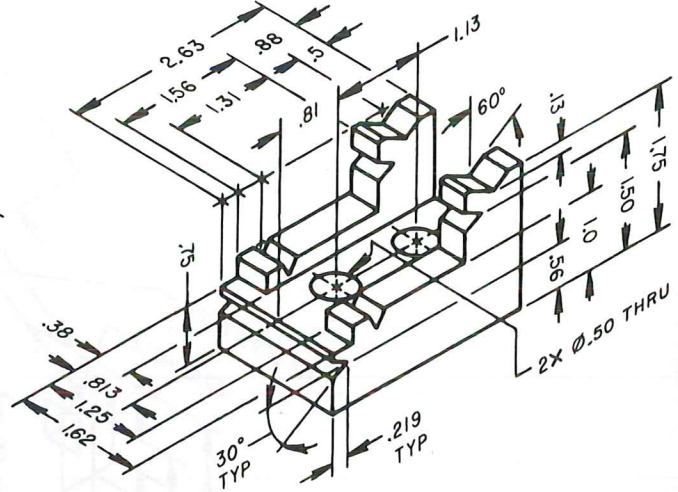


16. Plunger Check Valve



**Advanced**

17. Tool Block



18. Assembly Housing

